

## Midget Mills®

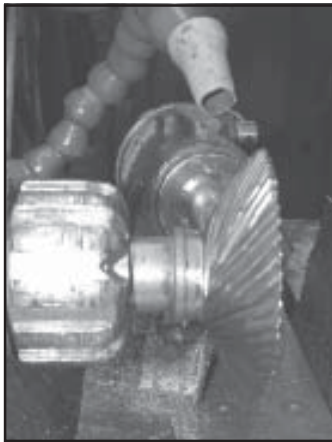

Over the years Severance Tool has become known not only as the originator of the ground flute rotary file, Midget Mill® and Chatterless-Countersinks™, but also the manufacturer and inventor of the highest quality unique rotary deburring and finishing tools. The many fluting geometries offered in the Severance Catalog are backed by the highest of fluting standards. These standards, quality craftsmen, quality machinery and the highest requirements for materials assure a quality tool that to the trained eye is no less than beautiful. There really is a difference!

**High Speed Steel** - In general, high speed steel rotary files are better for less rigid, hand operations where some chatter is likely. High speed steel Midget Mills® also come with a standard chip breaker, holding a good finish while improving the cut due to producing smaller chips. Severance high speed steel cutting tools are manufactured with quality M2 steel with a Rockwell of 63-65. Hard cutting edges are backed up by a tough, fatigue-resistant body to give excellent performance under the most demanding service conditions.



**Carbide** - Carbide rotary files are for operations in rigid environments where chatter is minimized and tool control is high. Severance uses special grades of carbide, which are formulated by custom suppliers and sintered at the Severance plant. The carbide is a special blend of Tungsten and Cobalt with a Rockwell A scale hardness of 91.7 to 92.2 which is comparatively harder and tougher for a longer tool life. These custom grades have been selected because they hold a fine cutting edge, which can be reground many times before the tool is used up. Carbide may be operated at many times the speed of steel tools and generally yields as much as five to ten times the service life.



**Tool Coatings** - Many high speed steel tools can be used where carbide might be easily chipped. Gold TiN-coated tools feature the same tough HSS bodies as the high speed steel line, but have a layer of super-hard titanium nitride deposited on their surfaces. These tools, available on special order, will out last regular high speed steel cutters, under most conditions, by a factor of about 3 to 1. Some of the other coatings available on our Carbide and H.S.S. tools include TiCN (titanium carbon nitride) and TiAlN (titanium aluminum nitride). Consult our engineering staff with your requirements and about other coatings.



**Grayhone™** - A process developed by Severance Tool which eliminates the need for a break-in period on tools. Grayhoned tools are ready to operate at full production speeds right out of the package. This saves time and money in a full range of production operations. Severance utilizes an additional proprietary process in the production of Grayhone™ tools. After the tools are sharpened with a grinding wheel, they are also honed before shipment to users. The Grayhone™ process also imparts a distinctive appearance to the tools that provides an added benefit. The dull gray color offers a built-in wear indicator that helps quality control efforts. When the cutting edges start to look shiny, it means that they are becoming dull, and the tools need replacement or resharpening. An overly dull tool causes bad part finishes, and increases the cost of resharpening.

## Midget Mill® Classifications



**H.S.S. Midget Mills® - Right hand spiral** tooth pattern with a **light chipbreaker** originated by Severance Tool. These tools can take more shock than carbide. Mainly used on non-work hardening materials. Materials applications can include M2, M42, cold and hot roll steels, aluminum, cast iron and bronze.



**Carbide Midget Mills® - Right hand spiral** tooth pattern invented by Rollin Severance, mainly intended for machine applications because of its deep radial flutes. Able to take a substantial amount of material off in an environment where the tool is not allowed to bounce or chatter out of control. Works best with materials applications using carbon steels, cast steels, gray irons, some stainless steel, tungsten, and nickel alloys.

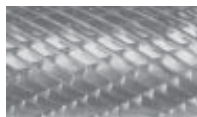

**Carbo -Mills™** - Features a **double cut** tooth pattern, first introduced by Severance Tool. Intended for applications where there is substantial stock removal and a rough to medium finish is required. Works best with ferrous, non-work hardening materials. Materials applications can include steels, aluminum, cast iron, and bronze.



**Sever-Cuts™** - Developed by Severance Tool, these tools feature a **super coarse** cut designed with very course deep positive flutes with a large flute radius to remove material without loading up. Works best with nonferrous materials including aluminum, copper, bronze, nickel, and magnesium. Can be used with either hand or machine operations.



**Tangent Mills™** - Are **left hand spiral**, right hand cutting, and are especially designed to control tool wandering on curved surfaces. Ideal for finishing holes in tubing. Works best with Ferrous, non-work hardening materials. Material applications can include M2, M42, cold & hot rolled steels, aluminum, cast iron, and bronze. See catalog page 16 for example.

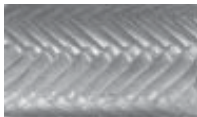

**d-burrs™** - Feature the **Herringbone™** cut invented by Severance Tool for fine finishing of plastic, aluminum, steel, and similar materials. The Herringbone™ Cut features alternating right hand and left hand flutes to give a fine finish on difficult deburring problems. See page 28 for standard shapes and sizes.

**Other tooth patterns available as a special cut upon request. Here are a few other examples.**

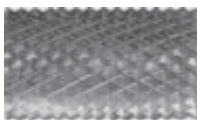

Rasp or Diamond Cut



Straight Cut



Chatterless Chamfer Cut™



Curve Tooth Cut

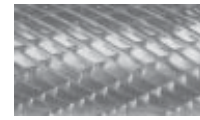

Tuff-Cut

## Pitches and their Cut Numbers

The pitches of teeth ground on Severance Midget Mills® are illustrated on page 6, in full scale. The chart at the right relates cut numbers to tool diameters for Fine, Standard, Coarse and Super Coarse pitches. Standard pitch will always be supplied unless otherwise specified. If an unlisted pitch is required, order by cut number.

This cut numbering system applies to Severance Midget Mills®, Junior Mills®, Carbo-Mills™, etc., and to hand files. Sever-Cut™ tools all have “super coarse” teeth.

Dia.	Fine	Std.	Coarse	Super Coarse*	Dia.	Fine	Std.	Coarse	Super Coarse*
	Cut #	Cut #	Cut #	(Teeth)		Cut #	Cut #	Cut #	Cut #
3/32"	2	3	5	Per	9/16"	5	7	9	
1/8"	3	4	5	Tool)	5/8"	5	7	9	10
3/16"	3	5	6		3/4"	6	8	10	12
1/4"	4	5	7	4	7/8"	6	8	10	
5/16"	4	6	7		1"	6	8	10	16
3/8"	4	6	8	6	1-1/8"	6	9	11	
7/16"	5	6	8		1-1/4"	6	9	11	
1/2"	5	7	9	8	1-1/2"	7	9	12	

\*Super Coarse Cuts are recommended for use on aluminum and other nonferrous materials for heavy, fast, stock removal.

1	2	3	4	5	6	7
.016 pitch 62 teeth/in.	.020 pitch 50 teeth/in.	.025 pitch 40 teeth/in.	.032 pitch 31 teeth/in.	.040 pitch 25 teeth/in.	.050 pitch 20 teeth/in.	.062 pitch 16 teeth/in.
8	9	10	11	12	13	14
.076 pitch 13 teeth/in.	.092 pitch 11 teeth/in.	.111 pitch 9 teeth/in.	.125 pitch 8 teeth/in.	.143 pitch 7 teeth/in.	.166 pitch 6 teeth/in.	.200 pitch 5 teeth/in.

## Midget Mills® Identification System

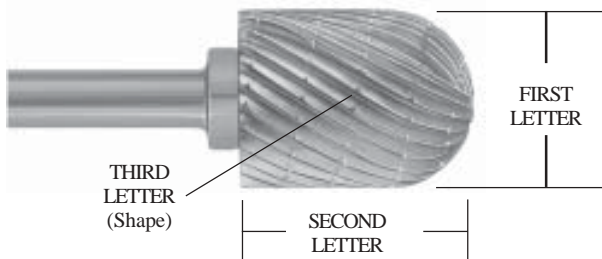

The third letter is the shape of the tool. In some cases, additional descriptive information is also part of the tool number . . . EC for End Cutting, 45 for a 45° angle, etc. All carbide tools carry the suffix, -W.

The First letter designates the largest diameter.  
The Second letter designates the length of cutting portion.  
The Third letter designates the general shape as illustrated.

A-1/8"	G-1/2"	M-1-1/8"	S-2"	Y-4-1/2"
B-3/16"	H-9/16"	N-1-1/4"	T-2-1/4"	Z-5"
C-1/4"	I-5/8"	O-1-3/8"	U-2-1/2"	
D-5/16"	J-3/4"	P-1-1/2"	V-3"	
E-3/8"	K-7/8"	Q-1-5/8"	W-3-1/2"	
F-7/16"	L-1"	R-1-3/4"	X-4"	

Midget Mills® are identified by a three-letter "tool number."  
The first and second letters specify cutting diameter and length.

## Standard Shape Designations

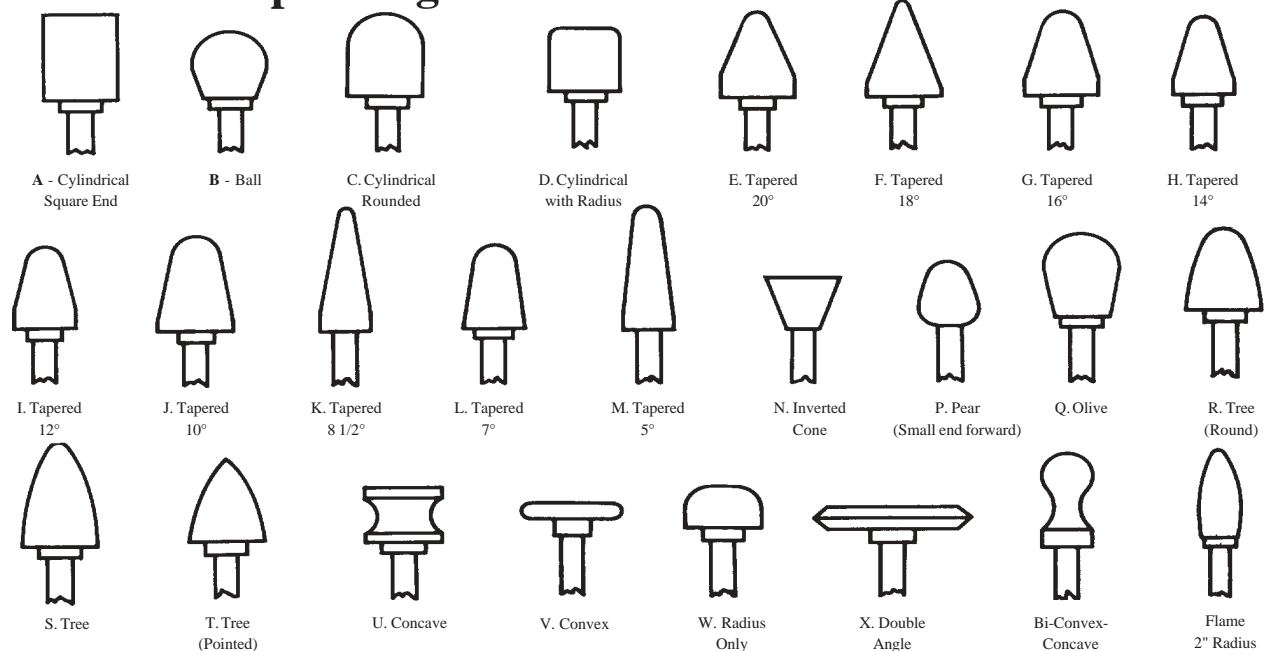

## Shape A Midget Mills®

Our founder, R.M. Severance, originated these tools in 1931. Today, throughout the industry, it is the standard, accepted, rotary cutting, burring and finishing tool. The Midget Mill® is efficient and practical for finishing up molds, smooth welds, clean castings, and smooth plastic edges in job or production operations. HSS Midget Mills® have Chip Breaker tooth patterns.







H.S.S. and Carbide Midget Mills®  
Come with 1/4" shanks



We're The Originators! We've Been "Copied" But Not Surpassed.



		 H.S.S. Midget-Mill® Single Cut Chip Breakers		 H.S.S. Midget-Mill® Single Cut-EC Chip Breakers		 Carbide Midget-Mill® Single Cut		 Carbide Midget-Mill®-EC Single Cut	
Head Dia.	Flute Length	Midget Mill® Name	EDP Order Number	Midget Mill® Name	EDP Order Number	Midget Mill® Name	EDP Order Number	Midget Mill® End Cut Name	EDP Order Number
1/8"	1/2"	AGA	22930	AGA-EC	22960	AGA-W	23280	AGA-EC-W	23300
1/8"	5/8"	-	-	-	-	AIA-W	23281	AIA-EC-W	23301
1/8"	3/4"	AJA	22931	AJA-EC	22961	-	-	-	-
1/8"	1"	ALA	22932	ALA-EC	22962	-	-	-	-
1/8"	1-1/4"	ANA	22933	ANA-EC	22963	-	-	-	-
1/8"	1-1/2"	APA	22934	APA-EC	22964	-	-	-	-
5/32"	5/8"	-	-	-	-	-	-	-	-
3/16"	1/2"	BGA	22935	BGA-EC	22965	BGA-W	23282	BGA-EC-W	23302
3/16"	5/8"	-	-	-	-	BIA-W	23283	BIA-EC-W	23303
3/16"	3/4"	BJA	22936	BJA-EC	22966	-	-	-	-
3/16"	1"	BLA	22937	BLA-EC	22967	-	-	-	-
1/4"	1/2"	CGA	22938	CGA-EC	22968	CGA-W	23284	CGA-EC-W	23304
1/4"	5/8"	-	-	-	-	CIA-W	23285	CIA-EC-W	23305
1/4"	3/4"	-	-	-	-	CJA-W	23286	CJA-EC-W	23306
1/4"	1"	CLA	22939	CLA-EC	22969	CLA-W	23287	CLA-EC-W	23307
1/4"	1-1/2"	CPA	22940	CPA-EC	22970	-	-	-	-
1/4"	1-3/4"	CRA	22941	CRA-EC	22971	-	-	-	-
5/16"	3/4"	-	-	-	-	DJA-W	23288	DJA-EC-W	23308
5/16"	1"	DLA	22942	DLA-EC	22972	DLA-W	23289	DLA-EC-W	23309
3/8"	3/4"	EJA	22943	EJA-EC	22973	EJA-W	23290	EJA-EC-W	23310
3/8"	1"	ELA	22944	ELA-EC	22974	ELA-W	23291	ELA-EC-W	23311
3/8"	1-1/2"	EPA	22945	EPA-EC	22975	EPA-W	23292	EPA-EC-W	23312
3/8"	2"	ESA	22946	ESA-EC	22976	-	-	-	-
7/16"	1"	FLA	22947	FLA-EC	22977	FLA-W	23293	FLA-EC-W	23313
1/2"	1/2"	GGA	22948	GGA-EC	22978	-	-	-	-
1/2"	1"	GLA	22949	GLA-EC	22979	GLA-W	23294	GLA-EC-W	23314
1/2"	1-1/4"	GNA	22950	GNA-EC	22980	-	-	-	-
1/2"	1-1/2"	GPA	22951	GPA-EC	22981	-	-	-	-
1/2"	2"	GSA	22952	GSA-EC	22982	-	-	-	-
5/8"	1"	ILA	22953	ILA-EC	22983	ILA-W	23295	ILA-EC-W	23315
3/4"	1/2"	JGA	22954	JGA-EC	22984	JGA-W	23296	JGA-EC-W	23316
3/4"	3/4"	JJA	22955	JJA-EC	22985	JJA-W	23297	JJA-EC-W	23317
3/4"	1"	JLA	22956	JLA-EC	22986	JLA-W	23298	JLA-EC-W	23318
3/4"	1-1/4"	JNA	22957	JNA-EC	22987	-	-	-	-
7/8"	1"	-	-	-	-	-	-	-	-
1"	1/4"	LCA	22958	LCA-EC	22988	-	-	-	-
1"	1"	LLA	22959	LLA-EC	22989	LLA-W	23299	LLA-EC-W	23319

## Shape A Midget Mills®

Carbide Midget Mills® are for operations in rigid environments where chatter is minimized and tool control is high. Severance uses special grades of carbide, which are formulated by custom suppliers and sintered at the Severance plant. The carbide is a special blend of Tungsten and Cobalt. These custom grades have been selected because they hold a fine cutting edge, which can be reground many times before the tool is used up. Carbide may be operated at many times the speed of steel tools and generally yields as much as five to ten times the service life. Carbide Midget Mills® have a Spiral tooth pattern; Carbo-Mills™ have a Double Cut tooth pattern; and carbide Sever-Cuts™ have a Super Coarse tooth Pattern.



H.S.S. and Carbide Midget Mills®  
Come with 1/4" shanks

Head Dia.	Flute Length	Carbide Carbo-Mill™ Double Cut		Carbide Carbo-Mill™-EC Double Cut		Carbide Sever-Cut™ Super Coarse	
		Carbo-Mill™ Name	EDP Order Number	Carbo-Mill™ End Cut Name	EDP Order Number	Sever-Cut™ Name	EDP Order Number
1/8"	1/2"	8A4-W	22380	8A4-EC-W	22386	-	-
1/8"	5/8"	8A14L-W	22381	8A14L-EC-W	22387	-	-
1/8"	3/4"	-	-	-	-	-	-
1/8"	1"	-	-	-	-	-	-
1/8"	1-1/4"	-	-	-	-	-	-
1/8"	1-1/2"	-	-	-	-	-	-
5/32"	5/8"	8A5-W	22382	8A5-EC-W	22388	-	-
3/16"	1/2"	-	-	-	-	-	-
3/16"	5/8"	8A6-W	22383	8A6-EC-W	22389	-	-
3/16"	3/4"	-	-	-	-	-	-
3/16"	1"	-	-	-	-	-	-
1/4"	1/2"	-	-	-	-	-	-
1/4"	5/8"	8A-W	22384	8A-EC-W	22390	-	-
1/4"	3/4"	-	-	-	-	CJA-W-4F	23680
1/4"	1"	8AL-W	22385	8AL-EC-W	22391	-	-
1/4"	1-1/2"	-	-	-	-	-	-
1/4"	1-3/4"	-	-	-	-	-	-
5/16"	3/4"	10A8-W	22480	10A8-EC-W	22496	-	-
5/16"	1"	10LA8-W	22481	10LA8-EC-W	22497	-	-
3/8"	3/4"	12A8-W	22482	12A8-EC-W	22498	EJA-W-6F	23681
3/8"	1"	12LA8-W	22483	12LA8-EC-W	22499	-	-
3/8"	1-1/2"	12XA8-W	22484	12XLA8-EC-W	22500	-	-
3/8"	2"	-	-	-	-	-	-
7/16"	1"	14A8-W	22485	14A8-EC-W	22501	-	-
1/2"	1/2"	-	-	-	-	-	-
1/2"	1"	16A8-W	22486	16A8-EC-W	22502	GLA-W-8F	23682
1/2"	1-1/4"	-	-	-	-	-	-
1/2"	1-1/2"	-	-	-	-	-	-
1/2"	2"	-	-	-	-	-	-
5/8"	1"	20A8-W	22487	20A8-EC-W	22503	ILA-W-8F	23683
3/4"	1/2"	24GA8-W	22488	24GA8-EC-W	22504	-	-
3/4"	3/4"	24JA8-W	22489	24JA8-EC-W	22505	-	-
3/4"	1"	24A8-W	22490	24A8-EC-W	22506	JLA-W-8F	23684
3/4"	1-1/4"	-	-	-	-	-	-
7/8"	1"	28A8-W	22492	28A8-EC-W	22508	-	-
1"	1/4"	-	-	-	-	-	-
1"	1"	32A8-W	22494	32A8-EC-W	22510	-	-



Carbide Carbo-Mill™-EC Double Cut

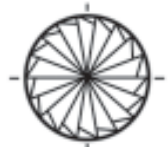

Carbide Sever-Cut™ Super Coarse

End Cut View Available as an option on many shapes.

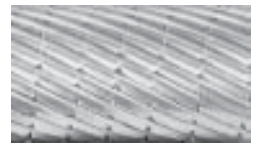

Chip breaker used on HSS Midget Mills®

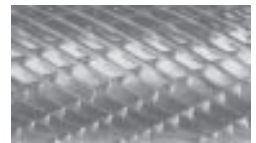

Double cut used on Carbo-Mills™

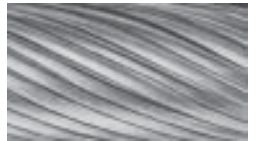

Spiral used on carbide Midget Mills® and Ecarbo-Mills™



Super coarse cut used on Sever-Cuts™

## Shape B Midget Mills®

Carbide tools have a full radius that blends to the shank, where as the H.S.S. tools have a 20° with C/L reverse angle on the back side of the cutting head.



H.S.S. and Carbide Midget Mills®  
Come with 1/4" shanks



H.S.S.  
Midget-Mill®  
Single Cut  
Chip Breakers

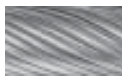

Carbide  
Midget-Mill®  
Single Cut

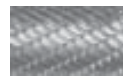

Carbide  
Carbo-Mill™  
Double Cut



Carbide  
Sever-Cut™  
Super Coarse

Head Dia.	Flute Length
1/8"	3/32"
3/16"	11/64"
1/4"	3/16"
5/16"	1/4"
3/8"	5/16"
7/16"	3/8"
1/2"	7/16"
9/16"	1/2"
5/8"	9/16"
3/4"	11/16"
7/8"	13/16"
1"	15/16"
1-1/4"	1-3/16"

Midget Mill® Name	EDP Order Number
AAB	22990
BBB	22991
CCB	22992
DDB	22993
EEB	22994
FFB	22995
GGB	22996
HHB	22997
IIB	22998
JJB	22999
KKB	23000
LLB	23001
NNB	23002

Midget Mill® Name	EDP Order Number
AAB-W	23320
BBB-W	23321
CCB-W	23322
DDB-W	23323
EEB-W	23324
FFB-W	23325
GGB-W	23326
-	-
IIB-W	23327
JJB-W	23328
-	-
LLB-W	23329
-	-

Carbo-Mill™ Name	EDP Order Number
8B4-W	22392
8B6-W	22393
8B-W	22394
10B8-W	22512
12B8-W	22513
14B8-W	22514
16B8-W	22515
-	-
20B8-W	22516
24B8-W	22517
-	-
32B8-W	22519
-	-

Sever-Cut™ Name	EDP Order Number
-	-
-	-
CCB-W-4F	23685
-	-
EEB-W-6F	23686
-	-
GGB-W-8F	23687
-	-
IIB-W-8F	23688
JJB-W-8F	23689
-	-
-	-

## Flex-Shank Midget Mills®



Many cases of puzzling, inside, blind, interrupted, winding, and around the corner; cleaning and deburring problems have been solved with Severance FLEX-SHANK Midget Mills®. We would like to help you! Submit details - sample parts if feasible. See pages 91-96 for more on special tools.



REF. # 53999

## Shape C Midget Mills®

Cylindrical shape mills with full radius end.  
Radius on end is one-half of tool diameter.



H.S.S.  
Midget-Mill®  
Single Cut  
Chip Breakers



Carbide  
Midget-Mill®  
Single Cut

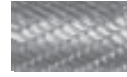

Carbide  
Carbo-Mill™  
Double Cut



Carbide  
Sever-Cut™  
Super Coarse

Head Dia.	Flute Length	Midget Mill® Name	EDP Order Number	Midget Mill® Name	EDP Order Number	Carbo-Mill™ Name	EDP Order Number	Sever-Cut™ Name	EDP Order Number
1/8"	1/2"	AGC	23003	AGC-W	23330	8C4-W	22395	-	-
1/8"	5/8"	-	-	AIC-W	23331	8CI4L-W	22396	-	-
5/32"	5/8"	-	-	-	-	8C5-W	22413	-	-
3/16"	1/2"	BGC	23004	-	-	-	-	-	-
3/16"	5/8"	-	-	BIC-W	23332	8C6-W	22397	-	-
1/4"	1/2"	-	-	CGC-W	23333	-	-	-	-
1/4"	5/8"	-	-	CIC-W	23334	8C-W	22414	-	-
1/4"	3/4"	-	-	-	-	-	-	CJC-W-4F	23690
1/4"	1"	CLC	23005	CLC-W	23335	8LC-W	22398	-	-
1/4"	1-1/2"	CPC	23006	-	-	-	-	-	-
1/4"	2-1/2"	CUC	23007	-	-	-	-	-	-
5/16"	3/4"	-	-	DJC-W	23336	10C8-W	22521	-	-
5/16"	1"	DLC	23008	DLC-W	23337	10LC8-W	22522	-	-
3/8"	3/4"	-	-	EJC-W	23338	12C8-W	22523	EJC-W-6F	23691
3/8"	1"	ELC	23009	ELC-W	23339	12MC8-W	22524	-	-
3/8"	1-1/2"	EPC	23010	EPC-W	23340	12LC8-W	22525	-	-
7/16"	1"	FLC	23011	FLC-W	23341	14C8-W	22526	-	-
1/2"	1"	GLC	23012	GLC-W	23342	16C8-W	22527	GLC-W-8F	23692
1/2"	1-1/2"	GPC	23013	-	-	-	-	-	-
5/8"	1"	ILC	23014	ILC-W	23343	20C8-W	22528	ILC-W-8F	23693
3/4"	1/2"	-	-	-	-	24GC8-W	22529	-	-
3/4"	3/4"	-	-	-	-	24MC8-W	22531	-	-
3/4"	1"	JLC	23015	JLC-W	23344	24C8-W	22533	JLC-W-8F	23694
3/4"	1-1/4"	JNC	23016	-	-	-	-	-	-
3/4"	1-1/2"	JPC	23017	-	-	-	-	-	-
1"	1"	-	-	-	-	-	-	-	-
1"	1"	-	-	-	-	32C8-W	22535	-	-
1	1-3/8"	LOC	23018	-	-	-	-	-	-

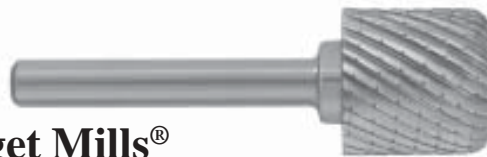

## Shape D Midget Mills®

Cylindrical shape mills with corner radius.



H.S.S.  
Midget-Mill®  
Single Cut  
Chip Breakers

Head Dia.	Flute Length	Midget Mill® Name	EDP Order Number
1/2"	1/2"	GGD-1/32R	23019
1/2"	1/2"	GGD-1/16R	23020
1/2"	1/2"	GGD-3/32R	23021
1/2"	1/2"	GGD-1/8 R.	23022
3/4"	3/4"	JJD-1/16R	23023
3/4"	3/4"	JJD-1/8R	23024
3/4"	3/4"	JJD-3/16R	23025
3/4"	3/4"	JJD-1/4R	23026



## Shape E Midget Mills®

Cone shape mills having  
20° C/L angle.



 H.S.S.  
Midget-Mill®  
Single Cut  
Chip Breakers

Head Dia.	Flute Length	Nose Pointed (P) or Radius
1/8"	3/16"	P
3/16"	3/16"	1/32"
1/4"	5/16"	P
3/8"	1/2"	P
1/2"	3/8"	5/32"
1/2"	1/2"	3/32"
3/4"	3/4"	9/64

Midget Mill® Name	EDP Order Number
ABE	23080
BBE	23081
CDE	23082
EGE	23083
GEE	23084
GGE	23085
JJE	23086

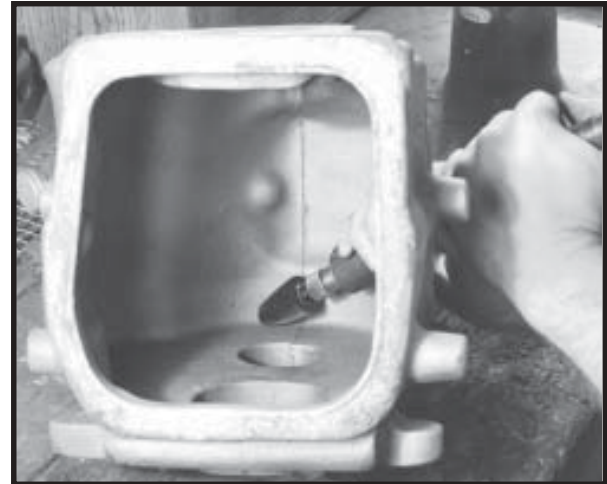

## Shape F Midget Mills®

Cone shape mills having  
18° C/L angle.



H.S.S. and Carbide Midget Mills®  
Come with 1/4" shanks

 H.S.S.  
Midget-Mill®  
Single Cut  
Chip Breakers

 Carbide  
Midget-Mill®  
Single Cut

 Carbide  
Carbo-Mill™  
Double Cut

Head Dia.	Flute Length
5/16"	3/8"
3/8"	3/8"
3/8"	9/16"
1/2"	7/16"
1/2"	5/8"
5/8"	3/4"
5/8"	7/8"
3/4"	7/8"
3/4"	1"
1"	1"
1"	1-3/8"

Midget Mill® Name	EDP Order Number
DEF	23087
EEF	23088
EHF	23089
GFF	23090
GIF	23091
IJF	23092
IKF	23093
JKF	23094
JLF	23095
LLF	23096
LOF	23097

Midget Mill® Name	EDP Order Number
—	—
—	—
—	—
—	—
—	—
—	—
IKF-W	23410
—	—
—	—
—	—

Carbo-Mill™ Name	EDP Order Number
—	—
—	—
—	—
—	—
—	—
—	—
20F8-W	22583
—	—
—	—
—	—





## Shape G Midget Mills®

Cone shape mills having  
16° C/L angle.



Head Dia.	Flute Length	Nose Pointed (P) or Radius
1/8"	3/16"	P
5/16"	3/8"	1/16"
3/8"	7/16"	5/64"
3/8"	5/8"	1/64"
1/2"	1/2"	5/32"
5/8"	3/4"	1/8"
3/4"	3/4"	7/32"

Midget Mill® Name	EDP Order Number
ABG	23098
DEG	23099
EFG	23100
EIG	23101
GGG	23102
IJG	23103
JJG	23104

REF. # 55339

### Midget Mills® with Special Guides

Midget Mills® are available in different Shapes, Sizes, and lengths of cut.

## Shape H Midget Mills®

Cone shape mills having  
14° C/L angle.

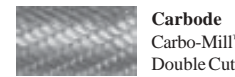

Head Dia.	Flute Length	Nose Pointed (P) or Radius
3/16"	5/16"	P
1/4"	3/8"	P
1/4"	1/2"	P
5/16"	5/8"	P
3/8"	1/2"	5/64"
3/8"	5/8"	.073 FLAT
3/8"	3/4"	P
1/2"	9/16"	9/64"
1/2"	7/8"	1/32"
5/8"	3/4"	5/32"

Midget Mill® Name	EDP Order Number
BDH	23105
—	—
CGH	23107
DIH	23106
EGH	23108
—	—
EJH	23109
GHH	23110
GKH	23111
IJH	23112

Midget Mill® Name	EDP Order Number
—	—
CEH-W	23400
—	—
—	—
—	—
—	—
EJH-W	23407
—	—
GKH-W	23408
—	—

Carbo-Mill™ Name	EDP Order Number
—	—
—	—
8H-W	22405
—	—
—	—
12H8-W	22581
—	—
—	—
16H8-W	22582
—	—

Sever-Cut™ Name	EDP Order Number
—	—
—	—
—	—
—	—
—	—
—	—
GKH-W-8F	23710
—	—



## Shape I Midget Mills®

Cone shape mills having  
12° C/L angle.



Head Dia.	Flute Length	Nose Pointed (P) or Radius
1/4"	5/16"	1/16"
3/8"	1/2"	3/32"
3/8"	3/4"	1/32"
1/2"	5/8"	9/64"
1/2"	1"	3/64"
5/8"	3/4"	3/16"
3/4"	9/16"	5/16"

Midget Mill® Name	EDP Order Number
CDI	23113
EGI	23114
EJI	23115
GII	23116
GLI	23117
IJI	23118
JHI	23119

REF. # 55337

### Extra Large Midget Mills

Midget Mills® are available in different shapes, sizes, and lengths of cut. Such as this large 4" diameter by 8" long Midget Mill®.

## Shape J Midget Mills®

Cone shape mills having 10° C/L angle.

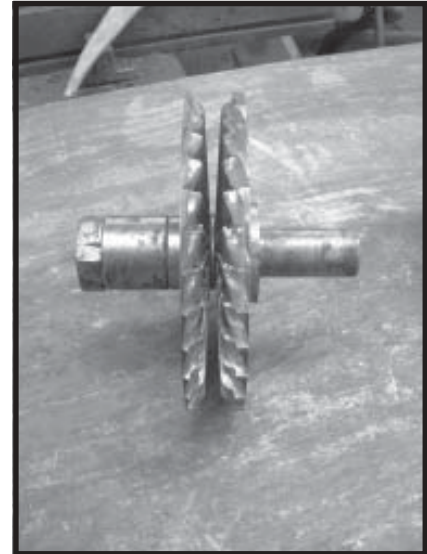

REF. # 55493

Here is an example of a larger milling cutter made by Severance to use in our milling department to put a special form on a standard tool.

Head Dia.	Flute Length	Nose Pointed (P) or Radius	Midget Mill® Name	EDP Order Number	Midget Mill® Name	EDP Order Number
3/16"	3/8"	1/32"	BEJ	23120	—	—
1/4"	5/16"	5/64"	CDJ	23121	—	—
1/4"	1/2"	3/64"	CGJ	23122	CGJ-W	23401
5/16"	3/4"	1/32"	DJJ	23123	—	—
3/8"	1/2"	1/8"	EGJ	23124	—	—
3/4"	5/8"	5/16"	JIJ	23125	—	—
3/4"	1"	7/32"	JLJ	23126	—	—
1"	3/4"	7/16"	LJJ	23128	—	—
1"	2-5/8"	1/16"	LUJ	23127	—	—

## Shape K Midget Mills®

Cone shape mills having 8-1/2° C/L angle.



Head Dia.	Flute Length	Nose Pointed (P) or Radius	Midget Mill® Name	EDP Order Number
1/8"	3/8"	P	AEK	23129
1/4"	3/8"	5/64"	CEK	23130
1/4"	5/8"	1/32"	CIK	23132
1/4"	3/4"	P	CJK	23131
5/16"	3/4"	3/64"	DJK	23133
3/8"	1"	3/64"	ELK	23134
1/2"	1-1/4"	1/16"	GNK	23135

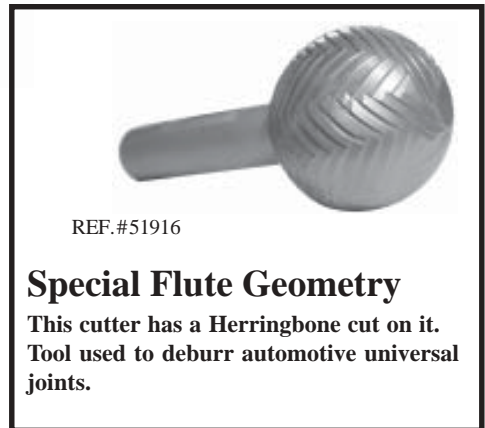

REF.#51916

### Special Flute Geometry

This cutter has a Herringbone cut on it. Tool used to deburr automotive universal joints.

## Shape L Midget Mills®

Cone shape mills having 7° C/L angle.

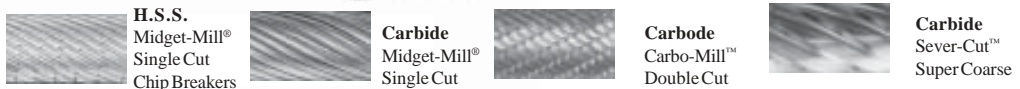
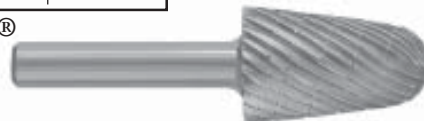

Head Dia.	Flute Length	Nose Pointed (P) or Radius	Midget Mill® Name	EDP Order Number	Midget Mill® Name	EDP Order Number	Carbo-Mill™ Name	EDP Order Number	Sever-Cut™ Name	EDP Order Number
3/16"	5/8"	1/64"	BIL	23136	—	—	—	—	—	—
1/4"	3/8"	.089"	—	—	—	—	8PL-W	22406	—	—
1/4"	5/8"	.055"	—	—	—	—	8LR-W	22408	—	—
1/4"	3/4"	1/32"	CJL	23137	CJL-W	23402	—	—	—	—
5/16"	3/4"	1/16"	DJL	23138	—	—	—	—	—	—
5/16"	7/8"	.055"	—	—	DKL-W	23405	10L8-W	22574	—	—
3/8"	1"	1/16"	ELL	23139	ELL-W	23406	12L8-W	22575	ELL-W-6F	23705
1/2"	1-1/8"	1/8"	—	—	—	—	16L8-W	22576	GML-W-8F	23706
1/2"	1-1/4"	3/32"	GNL	23140	GNL-W	23409	—	—	—	—
5/8"	3/4"	15/64"	IJL	23141	—	—	—	—	—	—
5/8"	7/8"	7/32"	IKL	23142	—	—	—	—	—	—
5/8"	1"	7/32"	—	—	—	—	20L8-W	22580	—	—
5/8"	1-3/16"	3/16"	—	—	—	—	20SL8-W	22577	INL-W-8F	23707
5/8"	1-5/16"	.171	—	—	—	—	20LL8-W	22578	IOL-W-8F	23708
3/4"	1-1/2"	7/32"	—	—	—	—	24L8-W	22579	JPL-W-8F	23709



## Shape M Midget Mills®

Cone shape mills having  
5° C/L angle.



H.S.S.  
Midget-Mill®  
Single Cut  
Chip Breakers

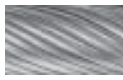

Carbide  
Midget-Mill®  
Single Cut

Head Dia.	Flute Length	Nose Pointed (P) or Radius	Midget Mill® Name	EDP Order Number	Midget Mill® Name	EDP Order Number
1/8"	1/2"	P	AGM	23143	—	—
3/16"	3/4"	1/32"	BJM	23144	—	—
1/4"	7/8"	3/64"	CKM	23145	CKM-W	23403
1/4"	1-1/4"	1/64"	CNM	23146	CNM-W	23404
3/8"	1"	7/64"	ELM	23147	—	—
3/8"	1-3/4"	1/32"	ERM	23148	—	—
1/2"	3/4"	13/64"	GJM	23149	—	—
1/2"	1"	5/32"	GLM	23150	—	—
1/2"	1-1/4"	5/32"	GNM	23151	—	—



REF. # 55494

Here is an example of a larger milling cutter made by Severance to use in our milling department to put a special form on a standard tool.

H.S.S. and Carbide Midget Mills®  
Come with 1/4" shanks

REF. # 50656

### Special Finning Cutters

These cutters originally designed to deburr the fins on aircraft motor heads during World War II  
Cutters used for stator and armature slots of electric motors and generators. Used for deburring in confined areas that are hard to reach.

## Shape N Midget Mills®

Inverted Cone shape mills having 5° to 18° C/L angle. Most commonly used without optional end cut.



Here is an example of a larger inverted cone milling cutter also made by Severance to use in our milling department to put flutes in a standard tool.

REF.#55523



H.S.S.  
Midget-Mill®  
Single Cut  
Chip Breakers



H.S.S.  
Midget-Mill®  
Single Cut-EC  
Chip Breakers



Carbide  
Midget-Mill®  
Single Cut



Carbide  
Midget-Mill®-EC  
Single Cut

Head Dia.	Flute Length	Included Angle	Midget Mill® Name	EDP Order Number	Midget Mill® End Cutting Name	EDP Order Number	Midget Mill® End Cutting Name	EDP Order Number	Midget Mill® End Cutting Name	EDP Order Number
1/4"	1/8"	36°	CAN	23152	CAN-EC	23169	-	-	-	-
1/4"	3/16"	28°	CBN	23153	CBN-EC	23170	-	-	-	-
1/4"	1/4"	20°	CCN	23154	CCN-EC	23171	-	-	-	-
1/4"	3/8"	14°	CEN	23155	CEN-EC	23172	-	-	-	-
1/4"	3/8"	20°	-	-	-	-	CEN-W	23411	CEN-W-EC	23416
1/4"	1/2"	10°	CGN	23156	CGN-EC	23173	-	-	-	-
3/8"	3/16"	36°	EBN	23157	EBN-EC	23174	-	-	-	-
3/8"	1/4"	28°	ECN	23158	ECN-EC	23175	-	-	-	-
3/8"	5/16"	20°	EDN	23159	EDN-EC	23176	EDN-W	23412	EDN-W-EC	23417
3/8"	3/8"	13°	-	-	-	-	-	-	-	-
3/8"	1/2"	10°	EGN	23160	EGN-EC	23177	-	-	-	-
1/2"	3/8"	20°	GEN	23161	GEN-EC	23178	-	-	-	-
1/2"	1/2"	14°	GGN	23162	GGN-EC	23179	-	-	-	-
1/2"	1/2"	16°	-	-	-	-	GGN-W	23413	GGN-W-EC	23418
1/2"	1/2"	28°	-	-	-	-	-	-	-	-
1/2"	1"	14°	GLN	23163	GLN-EC	23180	-	-	-	-
1/2"	1-1/8"	10°	GMN	23164	GMN-EC	23181	-	-	-	-
5/8"	3/8"	36°	IEN	23165	IEN-EC	23182	IEN-W	23414	IEN-W-EC	23419
5/8"	1/2"	28°	IGN	23166	IGN-EC	23183	-	-	-	-
5/8"	3/4"	18°	-	-	-	-	-	-	-	-
3/4"	1/2"	36°	JGN	23167	JGN-EC	23184	JGN-W	23415	JGN-W-EC	23420
3/4"	5/8"	30°	-	-	-	-	-	-	-	-
3/4"	5/8"	36°	JIN	23168	JIN-EC	23185	-	-	-	-
3/4"	3/4"	21°	-	-	-	-	-	-	-	-



REF. # 55373

Here is an example of a larger milling cutter made by Severance. The tool was 3" diameter by 4" length of cut.



REF. # 55354

## Special Extra Length Midget Mills

Midget Mills® are available in different shapes, sizes, and lengths of cut.

## Shape N Midget Mills®

Inverted Cone shape mills having 5° to 18° C/L angle. Most commonly used without optional end cut.



Carbo-Mill™  
Double Cut



Carbo-Mill™  
Double Cut-EC

Head Dia.	Flute Length	Included Angle	Carbo-Mill™ Double Cut Name	EDP Order Number	Carbo-Mill™ Double Cut-EC Name	EDP Order Number
1/4"	1/8"	36°	-	-	-	-
1/4"	3/16"	28°	8N-W	22409	8N-W-EC	22410
1/4"	1/4"	20°	-	-	-	-
1/4"	3/8"	14°	-	-	-	-
1/4"	3/8"	20°	-	-	-	-
1/4"	1/2"	10°	-	-	-	-
3/8"	3/16"	36°	-	-	-	-
3/8"	1/4"	28°	-	-	-	-
3/8"	5/16"	20°	-	-	-	-
3/8"	3/8"	13°	12N8-W	22584	12N8-W-EC	22588
3/8"	1/2"	10°	-	-	-	-
1/2"	3/8"	20°	-	-	-	-
1/2"	1/2"	14°	-	-	-	-
1/2"	1/2"	16°	-	-	-	-
1/2"	1/2"	28°	16N8-W	22585	16N8-W-EC	22589
1/2"	1"	14°	-	-	-	-
1/2"	1-1/8"	10°	-	-	-	-
5/8"	3/8"	36°	-	-	-	-
5/8"	1/2"	28°	-	-	-	-
5/8"	3/4"	18°	20N8-W	22586	20N8-W-EC	22590
3/4"	1/2"	36°	-	-	-	-
3/4"	5/8"	30°	24N8-W	22587	24N8-W-EC	22591
3/4"	5/8"	36°	-	-	-	-
3/4"	3/4"	21°	24JN8-W	22545	24JN8-W-EC	22592

H.S.S. and Carbide Midget Mills®  
Come with 1/4" shanks

## Inside Hole Deburring Cutters

**Inside Hole** - Place cutter head inside hole, bring back against inner wall edge; follow around inner contour of hole letting the shank act as a guide.



## High Speed Steel

Inside Style

Cutting Dia.	Neck Dia.	Shank Dia.	Severance Tool Name	EDP Order Number
7/32"	.109"	1/4"	7/32-IAD	35660
1/4"	.125"	1/4"	1/4-IAD	35661
5/16"	.156"	1/4"	5/16-IAD	35662
3/8"	.187"	1/4"	3/8-IAD	35663
7/16"	.250"	1/4"	7/16-IAD	35664
1/2"	.250"	1/4"	1/2-IAD	35665

## Tangent/Hole Deburring Cutters

**Outside Hole** -Place cutter in hole at right angle to tubing length. Geometrically (for any size hole) the diameter of the tool and the outside diameter of the part should be equal.



## High Speed Steel

Outside Style

Cutting Dia.	Cutting Length	Shank Dia.	Severance Tool Name	EDP Order Number
5/16"	1"	1/4"	DLA-LHS	35666
3/8"	1"	1/4"	ELA-LHS	35667
1/2"	1/2"	1/4"	GGA-LHS	35668
5/8"	1"	1/4"	ILA-LHS	35669
3/4"	3/4"	1/4"	JJA-LHS	35670
1"	1"	1/4"	LLA-LHS	35671

## Special Flute Geometry

Special flute geometry is used on this cutter to cut wafered cardboard.



REF. # 51926

## Shape P Midget Mills®

Pear shape mills with small end forward.



H.S.S.  
Midget-Mill®  
Single Cut  
Chip Breakers

Head Dia.	Flute Length	Midget Mill® Name	EDP Order Number
1/4"	5/16"	CDP	23027
5/16"	3/8"	DEP	23028
3/8"	7/16"	EFP	23029
1/2"	5/8"	GIP	23030
5/8"	1"	ILP	23031



H.S.S. and Carbide Midget Mills®  
Come with 1/4" shanks

## Shape Q Midget Mills®

The very useful olive-shaped mills.



H.S.S.  
Midget-Mill®  
Single Cut  
Chip Breakers

Head Dia.	Flute Length	Midget Mill® Name	EDP Order Number
3/16"	5/16"	BDQ	23032
1/4"	3/8"	—	—
1/4"	7/16"	CFQ	23033
5/16"	1/2"	DGQ	23034
3/8"	5/8"	EIQ	23035
3/8"	3/4"	EJQ	23036
7/16"	1"	—	—
1/2"	7/8"	GKQ	23037
5/8"	1"	ILQ	23038
3/4"	1"	JLQ	23039
1"	1-3/8"	LOQ	23040



Carbide  
Midget-Mill®  
Single Cut

Midget Mill® Name	EDP Order Number
BDQ-W	23372
CEQ-W	23373
—	—
—	—
EIQ-W	23374
—	—
—	—
GKQ-W	23375
ILQ-W	23376
JLQ-W	23377
—	—



Carbide  
Carbo-Mill™  
Double Cut

Carbo-Mill™ Name	EDP Order Number
8Q6-W	22399
8Q-W	22400
—	—
—	—
12Q8-W	22537
—	—
14Q8-W	22538
16Q8-W	22540
20Q8-W	22541
24Q8-W	22542
32Q8-W	22544



Carbide  
Sever-Cut™  
Super Coarse

Sever-Cut™ Name	EDP Order Number
—	—
—	—
—	—
—	—
EIQ-W-6F	23695
—	—
—	—
GKQ-W-8F	23696
ILQ-W-8F	23697
JLQ-W-8F	23698
—	—



REF.#55382



REF.#55373



### Special Shaped Midget Mills

Midget Mills® are available in different shapes, sizes, and lengths of cut.



## Shape R Midget Mills®

Tree-shape mills with rounded noses.

H.S.S. and Carbide Midget Mills®  
Come with 1/4" shanks



H.S.S.  
Midget-Mill®  
Single Cut  
Chip Breakers



Carbide  
Midget-Mill®  
Single Cut

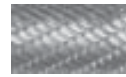

Carbide  
Carbo-Mill™  
Double Cut



Carbide  
Sever-Cut™  
Super Coarse

Head Dia.	Flute Length	Midget Mill® Name	EDP Order Number	Midget Mill® Name	EDP Order Number	Carbo-Mill™ Name	EDP Order Number	Sever-Cut™ Name	EDP Order Number
1/8"	7/16"	AFR	23041	AFR-W	23345	-	-	-	-
1/8"	1/2"	-	-	-	-	8R4-W	22401	-	-
3/16"	5/16"	BDR	23042	-	-	-	-	-	-
3/16"	1/2"	BGR	23043	-	-	-	-	-	-
1/4"	3/8"	CER	23044	-	-	-	-	-	-
1/4"	1/2"	-	-	CGR-W	23346	-	-	-	-
1/4"	5/8"	-	-	CIR-W	23347	8R-W	22402	-	-
1/4"	3/4"	CJR	23045	CJR-W	23348	-	-	CJR-W-4F	23699
1/4"	1"	CLR	23046	-	-	-	-	-	-
5/16"	1"	-	-	DLR-W	23350	-	-	-	-
3/8"	7/16"	EFR	23047	-	-	-	-	-	-
3/8"	3/4"	EJR	23048	EJR-W	23349	12R8-W	22546	EJR-W-6F	23700
3/8"	1"	ELR	23049	-	-	-	-	-	-
7/16"	1"	-	-	-	-	14R8-W	22547	-	-
1/2"	3/4"	GJR	23078	GJR-W	23351	16JR8-W	22548	-	-
1/2"	1"	GLR	23050	GLR-W	23352	16R8-W	22549	GLR-W-8F	23701
1/2"	1-1/8"	GMR	23051	-	-	-	-	-	-
5/8"	5/8"	IIR	23052	-	-	-	-	-	-
5/8"	1"	-	-	ILR-W	23353	20R8-W	22550	ILR-W-8F	23702
5/8"	1-1/8"	IMR	23053	-	-	-	-	IMR-W-8F	23703
3/4"	3/4"	JJR	23054	-	-	-	-	-	-
3/4"	1"	JLR	23055	JLR-W	23354	24R8-W	22551	-	-
3/4"	1-1/4"	JNR	23056	JNR-W	23355	24NR8-W	22553	JNR-W-8F	23704
3/4"	1-1/2"	-	-	JPR-W	23356	24PR8-W	22554	-	-
3/4"	1-5/8"	JQR	23057	-	-	-	-	-	-
1"	1-3/8"	-	-	-	-	32R8-W	22555	-	-
1-1/8"	1-3/4"	MRR	23058	-	-	-	-	-	-
1-1/4"	2"	NSR	23059	-	-	-	-	-	-

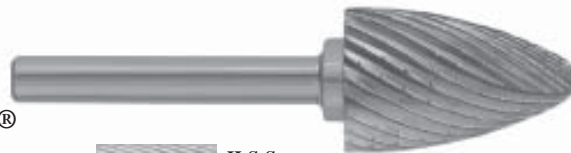

## Shape S Midget Mills®

Tree shape mills with a small radius nose.



H.S.S.  
Midget-Mill®  
Single Cut  
Chip Breakers

Head Dia.	Flute Length	Severance Tool Name	EDP Order Number
1/8"	3/8"	AES	23060
3/16"	1/2"	BGS	23061
1/4"	3/4"	CJS	23062
3/8"	3/4"	EJS	23063
1/2"	1"	GLS	23064
5/8"	1-1/8"	IMS	23065
3/4"	1-1/4"	JNS	23066
1"	1-5/8"	LQS	23067
1-1/4"	2"	NSS	23068



## Shape T Midget Mills®

Tree-shape mills with a pointed noses.



REF.#55352

### Coarse Cut Midget Mills®

Midget Mill® tools can be made in coarse cut for a variety of non-ferrous materials such as wood, aluminum, and certain plastics.. Also see Sever-Cut™ Midget Mills® for non-ferrous materials.

H.S.S. and Carbide Midget Mills®  
Come with 1/4" shanks



H.S.S. Midget-Mill® Single Cut Chip Breakers



Carbide Midget-Mill® Single Cut



Carbide Carbo-Mill™ Double Cut

Head Dia.	Flute Length	Midget Mill® Name	EDP Order Number	Midget Mill® Name	EDP Order Number	Carbo-Mill™ Name	EDP Order Number
1/8"	1/2"	—	—	—	—	8T4-W	22403
1/4"	1/2"	CGT	23069	CGT-W	23357	—	—
1/4"	5/8"	—	—	CIT-W	23358	8T-W	22404
1/4"	3/4"	CJT	23070	CJT-W	23359	—	—
5/16"	3/4"	—	—	DJT-W	23360	10T8-W	22557
3/8"	5/8"	EIT	23701	—	—	—	—
3/8"	3/4"	EJT	23702	EJT-W	23361	12T8-W	22558
7/16"	1"	—	—	—	—	14T8-W	22559
1/2"	3/4"	GJT	23073	GJT-W	23362	16JT8-W	22560
1/2"	1"	GLT	23074	GLT-W	23363	16T8-W	22561
1/2"	1-1/8"	GMT	23075	—	—	—	—
5/8"	1"	ILT	23076	ILT-W	23364	20T8-W	22562
3/4"	1"	JLT	23077	JLT-W	23365	24T8-W	22563
3/4"	1-1/2"	—	—	JPT-W	23366	24PT8-W	22565
1"	1-3/8"	—	—	—	—	32T8-W	22567

## Shape U Midget Mills®

Concave radius mills with cutting teeth on radius only.



H.S.S. Midget-Mill® Single Cut Chip Breakers



Carbide Midget-Mill® Single Cut



Carbide Carbo-Mill™ Double Cut

Head Dia.	Flute Length	Radius	Midget Mill® Name	EDP Order Number	Midget Mill® Name	EDP Order Number	Carbo-Mill™ Name	EDP Order Number
1/4"	1/8"	3/32"	CAU	23186	—	—	—	—
1/4"	3/16"	3/16"	CBU	23187	—	—	—	—
1/4"	1/8"	1/16"x4 PL	CZU	23188	—	—	—	—
5/16"	3/16"	3/32"	DBU	23189	—	—	—	—
3/8"	1/8"	1/16"	EAU	23190	—	—	—	—
3/8"	3/16"	1/8"	EBU	23191	—	—	—	—
3/8"	1/4"	3/16"	ECU	23192	—	—	—	—
3/8"	5/16"	1/4"	EDU	23193	—	—	—	—
7/16"	1/4"	5/32"	FCU	23194	—	—	—	—
1/2"	1/4"	3/16"	GCU	23195	GCU-W	23421	—	—
1/2"	5/16"	1/4"	GDU	23196	GDU-W	23422	—	—
1/2"	3/8"	5/16"	GEU	23197	GEU-W	23423	16U8-W	22556
1/2"	7/16"	3/8"	GFU	23198	GFU-W	23424	—	—
5/8"	1/2"	7/16"	IGU	23199	—	—	—	—
3/4"	3/8"	1/4"	JEU	23200	—	—	—	—
3/4"	7/16"	5/16"	JFU	23201	—	—	—	—
3/4"	1/2"	3/8"	JGU	23202	—	—	—	—
3/4"	5/8"	1/2"	JIU	23203	—	—	—	—
7/8"	5/8"	7/16"	KIU	23204	—	—	—	—
7/8"	3/4"	5/8"	KJU	23205	—	—	—	—





H.S.S.  
Midget-Mill®  
Single Cut  
Chip Breakers



## Shape V Midget Mills®

Convex with cutting teeth on the radius only.

Head Dia.	Flute Length	Radius	Severance Tool Name	EDP Order Number
1/4"	3/8"	1/4"	CEV	23206
5/8"	7/16"	1/4"	IFV	23207
3/4"	1/2"	1/2"	JGV	23208
1"	3/16"	3/32"	LBV	23209
1-1/4"	7/8"	5/8"	NKV	23210

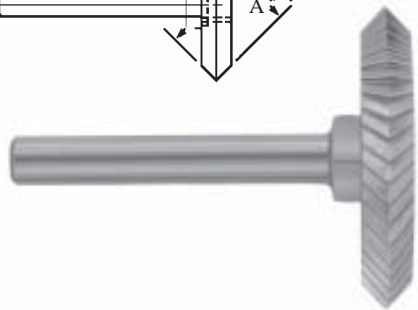
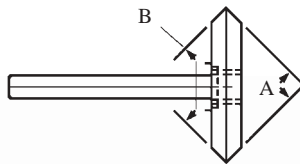

H.S.S.  
Midget-Mill®  
Single Cut  
Chip Breakers



## Shape X Midget Mill®

Convex shape mills. This shape combines forward and reverse angles as listed in the "Included Angle" column. Forward angle is given first, followed by reverse angle. Angles are given with C/L. Special angles may be obtained at a nominal extra charge.

Head Dia.	Head Length	Centerline Angles		Severance Tool Name	EDP Order Number
		A	B		
1/4"	1/4"	20°	20°	CCX	23221
1/4"	3/8"	80°	10°	CEX	23217
5/16"	1/4"	30°	30°	DCX	23222
3/8"	1/4"	60°	60°	ECX	23223
1/2"	1/4"	50°	50°	GCX	23224
5/8"	1/4"	60°	60°	ICX	23225
5/8"	5/8"	40°	20°	IIX	23218
3/4"	1/2"	120°	60°	JGX	23219
1"	1/4"	90°	90°	LCX	23226
1"	3/4"	90°	30°	LJX	23220
1-1/2"	1/4"	60°	60°	PCX-30	23227
1-1/2"	1/4"	90°	90°	PCX-45	23228
1-1/2"	1/4"	120°	120°	PCX-60	23229



H.S.S.  
Midget-Mill®  
Single Cut  
Chip Breakers



## Shape W Midget Mills®

Cylindrical shape mills with cutting teeth on the end radius only. They feature a non-fluted (safe) area at the center of the end face and on the straight cylindrical sides adjacent to the radius. Use for finishing fillets and many other similar applications.

Head Dia.	Flute Length	Radius	Severance Tool Name	EDP Order Number
1/4"	1/8"	1/16"	CAW	23211
5/16"	1/4"	1/16"	DCW	23212
3/8"	5/16"	3/32"	ECW	23213
1/2"	3/8"	5/32"	GEW	23214
7/8"	1/2"	1/4"	KGW	23215
1"	1/2"	5/16"	LGW	23216



H.S.S.  
Midget-Mill®  
Single Cut  
Chip Breakers



## Shape BI Midget Mills®

Convex with cutting teeth on the radius only.

Head Dia.	Flute Length	Radius	Severance Tool Name	EDP Order Number
3/16"	5/8"	5/16" x 1/2"	BIRU	23230
1/4"	3/4"	1-1/2" x 1/2"	CJCU	23231
1/4"	1"	3/4" x 3/4"	CLRU	23232
1/4"	1"	1" x 1/2"	CLTU	23233
5/16"	1-1/8"	1" x 1"	DMRU	23234
3/8"	1"	3/16" x 1-1/4"	ELCU	23235
3/8"	1"	1/2" x 3/4"	ELTU	23236
1/2"	7/8"	1/4" x 3/8"	GKCU	23237



## Shape FL Midget Mills®

A very handy shape for blending operations.



Carbide  
Midget-Mill®  
Single Cut

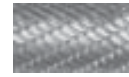

Carbide  
Carbo-Mill™  
Double Cut

Head Dia.	Flute Length	Midget Mill® Name	EDP Order Number	Carbo-Mill™ Name	EDP Order Number
1/4"	5/8"	CIFL-W	23367	8GN-W	22415
5/16"	3/4"	DJFL-W	23368	10FL8-W	22569
1/2"	1-1/4"	GNFL-W	23369	16FL8-W	22570
5/8"	1-7/16"	IOFL-W	23370	20FL8-W	22571
3/4"	1-5/8"	JQFL-W	23371	24FL8-W	22572

## Long Shank Midget Mills®

1/4" Shank Diameter – 8" Shank Length

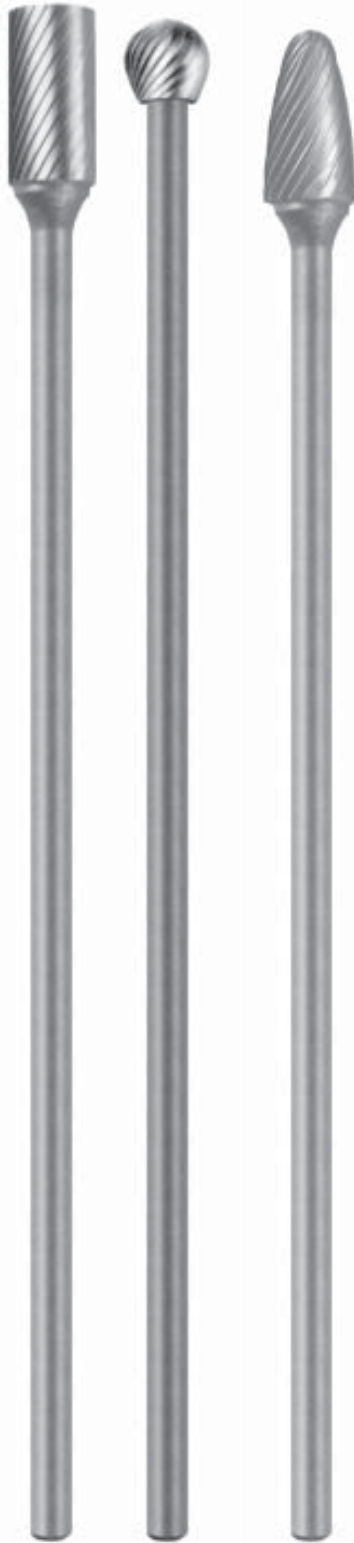

Other shank lengths available upon request



## Special Flute Geometry

Special flute geometry is used on this cutter to deburr part.

REF.#51926



H.S.S. Midget-Mill®



Carbide Midget-Mill®

Head Dia.	Flute Length	Nose Point, Flat, or Radius
-----------	--------------	-----------------------------

**Cylindrical, Plain Nose, Shape "A"**

1/4"	1"	-
3/8"	1"	-
1/2"	1"	-

**Cylindrical, End Cutting, Shape "A"**

1/4"	1"	-
3/8"	1"	-
1/2"	1"	-

**Ball, Shape "B"**

1/4"	3/16"	-
3/8"	5/16"	-
1/2"	7/16"	-

**Cylindrical, Ball Nose, Shape "C"**

1/4"	1"	-
3/8"	1"	-
1/2"	1"	-

**Tree, Radius Nose, Shape "R"**

1/4"	1/2"	-
3/8"	3/4"	-
1/2"	1"	-

**Tree, Pointed Nose, Shape "T"**

1/4"	3/4"	P
3/8"	3/4"	P
1/2"	1"	P

**Flame, Shape "FL"**

5/16"	3/4"	-
1/2"	1-1/4"	-

**Olive, Shape "Q"**

1/4"	7/16"	-
3/8"	5/8"	-
1/2"	7/8"	-

**Cone, 14° Included, Shape "L"**

3/8"	1"	.063"
------	----	-------

**Cone, 20° Included, Shape "J"**

5/16"	3/4"	.031"
-------	------	-------

**Cone, 28° Included, Shape "H"**

1/4"	1/2"	P
1/2"	1"	F

Midget-Mill® Name	EDP Order Number
-------------------	------------------

CLAx8	23730
ELAx8	23731
GLAx8	23732

CLA-ECx8	23733
ELA-ECx8	23734
GLA-ECx8	23735

CCBx8	23736
EEBx8	23737
GGBx8	23738

CLCx8	23739
ELCx8	23740
GLCx8	23741

CJRx8	23742
EJRx8	23743
GLRx8	23744

CJTx8	23745
EJTx8	23746
GLTx8	23747

DJFLx8	23748
GNFLx8	23749

CFQx8	23750
EIQx8	23751
GKQx8	23752

ELLx8	23755
-------	-------

DJx8	23754
------	-------

CGHx8	23753
GLHx8	23756

Midget-Mill® Name	EDP Order Number
-------------------	------------------

CLAx8	23780
ELAx8	23781
GLAx8	23782

CLA-ECx8	23783
ELA-ECx8	23784
GLA-ECx8	23785

CCBx8	23786
EEBx8	23787
GGBx8	23788

CLCx8	23789
ELCx8	23790
GLCx8	23791

CJRx8	23792
EJRx8	23793
GLRx8	23794

CJTx8	23795
EJTx8	23796
GLTx8	23797

DJFLx8	23798
GNFLx8	23799

CFQx8	23800
EIQx8	23801
GKQx8	23802

ELLx8	23805
-------	-------

DJx8	23804
------	-------

CGHx8	23803
GLHx8	23806

## Carbo-Mills™ & Ecarno-Mills™

3/16" Shank Diameter –

2" Overall Length

Carbo-Mills™ · tough durable carbide features the Severance Double-Cut flute design.

Ecarno-Mills™ · carbide with standard spiral flute design.



Carbide  
Carbo-Mill™



Carbide  
Ecarno-Mills®

Head Dia.	Flute Length	Nose Point, Flat, or Radius
-----------	--------------	-----------------------------

Carbo-Mill™ Name	EDP Order Number
------------------	------------------

Ecarno-Mill™ Name	EDP Order Number
-------------------	------------------



Shape "A"

### Cylindrical, Plain Nose, Shape "A"

1/8"	3/8"	-
3/16"	1/2"	-

6A4-W	22280
6A-W	22281

SA-82	21920
SA-81	21921



Shape "B"

### Cylindrical, End Cutting, Shape "A"

1/8"	3/8"	-
3/16"	1/2"	-

6A4-EC-W	22282
6A-EC-W	22283

SB-82	21922
SB-81	21923



Shape "C"

### Ball, Shape "B"

1/8"	3/32"	-
3/16"	11/64"	-

6B4-W	22284
6B-W	22285

SD-82	21924
SD-81	21925

### Cylindrical, Ball Nose, Shape "C"

1/8"	3/8"	-
3/16"	1/2"	-

6C4-W	22286
6C-W	22287

SC-82	21926
SC-81	21927



Shape "L", "H", "J", and "M"

### Olive, Shape "Q"

3/16"	9/32"	-
3/16"	3/8"	-

-	-
6Q-W	22288

SE-81	21928
-	-



Shape "N"

### Tree, Radius Nose, Shape "R"

3/16"	1/2"	.048"
-------	------	-------

6R-W	22289
------	-------

SF-81	21929
-------	-------



Shape "Q"

### Tree, Pointed Nose, Shape "T"

3/16"	1/2"	P
-------	------	---

6T-W	22290
------	-------

SG-81	21930
-------	-------

### Cone, 7° Included, Shape "H"

3/16"	1/2"	.067"
-------	------	-------

6H-W	22293
------	-------

-	-
---	---

### Cone, 10° Included, Shape "M"

3/16"	1/4"	.031"
3/16"	5/16"	.031"

6M4-W	22292
6M-W	22291

-	-
-	-

### Cone, 12° Included, Shape "J"

3/16"	7/16"	F
3/16"	5/8"	.067"

6J-W	22295
-	-

-	-
SM-81	21932



Shape "R"

### Cone, 14° Included, Shape "L"

3/16"	3/8"	.054"
3/16"	7/16"	.031"

6L-W	22294
-	-

-	-
SL-81	21931



Shape "T"

### Flame, Shape "FL"

3/16"	1/4"	-
3/16"	5/16"	-

6GN-W	22296
-	-

-	-
SH-81	21933



Tapered End 90° Included

### Inverted Cone, Plain End, Shape "N"

3/16"	3/16"	-
-------	-------	---

6N-W	22297
------	-------

SN-81	21934
-------	-------

### Inverted Cone, End Cutting, Shape "N"

3/16"	3/16"	-
-------	-------	---

6N-EC-W	22298
---------	-------

SN-82	21935
-------	-------



Tapered End 60° Included

### Tapered End, 60° Included Angle Double End

3/16"	5/32"	P
-------	-------	---

6Z-W-DE	20622
---------	-------

SJ-81	21937
-------	-------

### Tapered End, 90° Included Angle Double End

3/16"	3/32"	P
-------	-------	---

6Y-W-DE	20682
---------	-------

SK-81	21936
-------	-------

## Carbo-Mills™ & Ecarno-Mills™

1/8" Shank Diameter –  
1-1/2" Overall Length

Carbo-Mills™ · tough durable carbide features the Severance Double-Cut flute design.

Ecarno-Mills™ · carbide with standard spiral flute design.



Shape "A"



Shape "A"



Shape "B"



Shape "C"



Shape "C"



Shape "L", "H", "J", "M"



Shape "N",



Shape "Q",



Shape "R"



Shape "T"



Tapered End 90° Incl



Tapered End 60° Incl

Head Dia.	Flute Length	Nose Point, Flat, or Radius
-----------	--------------	-----------------------------

**Cylindrical, Plain Nose, Shape "A"**

1/16"	1/4"	-
3/32	7/16"	-
3/32"	1/2"	-
1/8"	9/16"	-

**Cylindrical, End Cutting, Shape "A"**

1/16"	1/4"	-
3/32	7/16"	-
3/32"	1/2"	-
1/8"	9/16"	-
1/8"	3/8"	-

**Ball, Shape "B"**

3/32"	5/64"	-
1/8"	3/32"	-

**Cylindrical, Ball Nose, Shape "C"**

3/32"	1/2"	-
3/32"	7/16"	-
1/8"	9/16"	-

**Olive, Shape "Q"**

1/8"	7/32"	-
------	-------	---

**Tree, Radius Nose, Shape "R"**

1/8"	1/4"	.031"
1/8"	1/2"	.031"

**Tree, Radius Nose, Shape "S"**

1/8"	1/2"	.031"
------	------	-------

**Tree, Pointed Nose, Shape "T"**

1/8"	1/4"	P
1/8"	3/8"	P
1/8"	1/2"	P

**Cone, 7° Included, Shape "H"**

1/8"	1/2"	.031"
1/8"	5/8"	.031"

**Cone, 8° Included, Shape "L"**

1/8"	3/8"	.039"
1/8"	1/2"	F

**Cone, 10° Included, Shape "M"**

3/32"	1/4"	.016"
1/8"	5/16"	.031"

**Cone, 12° Included, Shape "J"**

1/8"	11/32"	F
1/8"	7/16"	F

**Cone, 14° Included, Shape "L"**

1/8"	3/8"	.019"
1/8"	7/16"	.010"

**Flame, Shape "FL"**

1/8"	1/4"	-
------	------	---

**Inverted Cone, Plain End, Shape "N"**

3/32"	1/8"	-
1/8"	3/16"	-

**Inverted Cone, End Cutting, Shape "N"**

3/32"	1/8"	-
1/8"	3/16"	-

**Tapered End, 60° Included Angle Double End**

1/8"	"	P
------	---	---

**Tapered End, 90° Included Angle Double End**

1/8"	"	P
------	---	---



Carbide Carbo-Mill™

Carbo-Mill™ Name	EDP Order Number
------------------	------------------

-	-
-	-
4A3-W	22230
4A-W	22231

-	-
-	-
4A3-EC-W	22232
4A-EC-W	22233
-	-



Carbide Ecarno-Mills®

Ecarno-Mill™ Name	EDP Order Number
-------------------	------------------

SA-41	21770
SA-42	21771
-	-
SA-43	21772

SB-42	21774
SB-43	21775
-	-
SB-44	21776
*SB-41	21773

SD-41	21777
SD-42	21778

-	-
SC-41	21779
SC-42	21780

SE-41	21781
-------	-------

SF-41	21783
SF-42	21782

-	-
---	---

SG-41	21786
SG-43	21785
SG-44	21784

-	-
SM-43	21787

SL-41	21791
SL-42	21790

-	-
-	-

SM-41	21789
-	-

-	-
SM-42	21788

SH-41	21792
-------	-------

SN-41	21794
SN-42	21793

SN-41	21794
SN-42	21793

SJ-41	21798
-------	-------

SK-41	21797
-------	-------

• SB-41 (EDP #21773) is only available in a double ended style

## Carbo-Mills™ &

## Ecarno-Mills™

3/32" Shank Diameter –

2" Overall Length

**Carbo-Mills™** - tough durable carbide features the Severance Double-Cut flute design.

**Ecarno-Mills™** - carbide with standard spiral flute design.

Uses - Carbo-Mills™ cover a wide range of uses such as: removing gates, fins, and risers; breaking sharp corners and edges; machining carbon; finishing castings of any material; working fillets, radii, and grooves; deburring oil holes; blending welded and assembled parts; and removing weld beads. They are ideal for the production deburring and machining of parts made from materials that are abrasive or tough, or having hardness up to 60 "C" Rockwell. They are equally useful to maintenance men, and to tooling departments that produce dies, molds, and metal patterns.

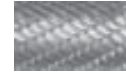

Carbide  
Carbo-Mill™



Carbide  
Ecarno-Mills®

Head Dia.	Flute Length	Nose Point, Flat, or Radius
-----------	--------------	-----------------------------

Carbo-Mill™ Name	EDP Order Number
------------------	------------------

Ecarno-Mill™ Name	EDP Order Number
-------------------	------------------

### Cylindrical, Plain Nose, Shape "A"

1/16"	1/4"	-
3/32"	3/8"	-

3A2-W	22180
3A-W	22181

SA-61	21720
SA-63	21721

### Cylindrical, End Cutting, Shape "A"

1/16"	1/4"	-
3/32"	3/8"	-

3A2-EC-W	22182
3A-EC-W	22183

SB-61	21723
SB-63	21724

### Ball, Shape "B"

1/16"	3/64"	-
3/32"	5/64"	-

3B2-W	22184
3B-W	22185

SD-61	21726
SD-63	21727

### Cylindrical, Ball Nose, Shape "C"

1/16"	1/4"	-
3/32"	3/8"	-

3C2-W	22186
3C-W	22187

SC-61	21728
SC-63	21729

### Olive, Shape "Q"

3/32"	1/8"	-
-------	------	---

3Q-W	22188
------	-------

SE-61	21730
-------	-------

### Tree, Radius Nose, Shape "R"

3/32"	5/16"	.023"
-------	-------	-------

3R-W	22189
------	-------

SF-61	21731
-------	-------

### Tree, Pointed Nose, Shape "T"

3/32"	3/8"	P
-------	------	---

3T-W	22190
------	-------

SG-61	21732
-------	-------

### Cone, 7° Included, Shape "H"

3/32"	5/16"	.031"
-------	-------	-------

3H-W	22193
------	-------

SM-63	21735
-------	-------

### Cone, 10° Included, Shape "M"

3/32"	3/16"	F
3/32"	1/4"	.016

3M3-W	22192
3M-W	22191

SM-61	21734
SM-62	21733

### Cone, 12° Included, Shape "J"

3/32"	1/4"	F
-------	------	---

3J-W	22195
------	-------

SL-61	21737
-------	-------

### Cone, 14° Included, Shape "L"

3/32"	1/4"	.015"
-------	------	-------

3L-W	22194
------	-------

SL-62	21736
-------	-------

### Flame, Shape "FL"

3/32"	1/8"	-
-------	------	---

3GN-W	22196
-------	-------

SH-61	21738
-------	-------

### Inverted Cone, Plain End, Shape "N"

3/32"	1/8"	-
-------	------	---

3N-W	22197
------	-------

SN-61	21739
-------	-------

### Inverted Cone, End Cutting, Shape "N"

3/32"	1/8"	-
-------	------	---

3N-EC-W	22198
---------	-------

SN-62	21740
-------	-------

### Tapered End, 60° Included Angle Double End

3/32"	1/8"	P
-------	------	---

3Z-W-DE	20620
---------	-------

SJ-61	21741
-------	-------

### Tapered End, 90° Included Angle Double End

3/32"	1/8"	P
-------	------	---

3Y-W-DE	20680
---------	-------

SK-61	21742
-------	-------

Shape "A"

Shape "B"

Shape "C"

Shape "T",

Shape "N",

Shape "R"

Shape "H", "J", "L", and "M"

Tapered End 90° Included

Tapered End 60° Included

## Specialty Midget Mills®

## Junior Mills®



### Junior Mills®

#### 1/8" Shank Diameter – 1-5/8" Overall Length

These Popular tools are used for finishing the intricate patterns and parts, with surfaces difficult to reach with the large Midget Mills®. Junior Mills® are recommended for metal, wood, and plastic part finishing. Use them in place of grinding wheels or mounted points, they will cut faster, make real chips, and leave excellent finishes. Tools can be reground many times.

### Junior Mills®



Head Dia.	Head Length	Nose Point, Flat or Radius	Tool Shape	H.S.S. Tool Name	EDP Order Number	Carbide Tool Name	EDP Order Number
3/16"	5/8"	-	Cylindrical, Plain End	JR-1	22721	JR-1-W	22821
3/16"	5/8"	-	Cylindrical, End Cutting	JR-1-EC	22724	JR-1-EC-W	22824
1/4"	1/2"	-	Cylindrical, Plain End	JR-2	22722	JR-2-W	22822
1/4"	1/2"	-	Cylindrical, End Cutting	JR-2-EC	22725	JR-2-EC-W	22825
1/8"	3/32"	-	Ball	JR-3	22726	JR-3-W	22826
1/4"	3/16"	-	Ball	JR-4	22727	JR-4-W	22828
3/16"	5/8"	-	Cylindrical, Ball Nose	JR-5	22730	JR-5-W	22830
3/16"	5/8"	P	Cone Forward Angle	JR-6	22741	JR-6-W	22841
3/16"	3/8"	-	Olive	JR-7	22732	JR-7-W	22832
1/8"	5/16"	.031"	Tree, Rounded Nose	JR-8	22734	JR-8-W	22834
3/16"	3/8"	.047"	Tree, Rounded Nose	JR-9	22735	JR-9-W	22835
3/16"	3/8"	-	Flame	JR-10	22738	JR-10-W	22838
3/8"	3/64"	-	Wheel, Cylindrical, Plain End	JR-11	22745	JR-11-W	22845
3/8"	3/64"	-	Wheel, Cylindrical, End Cutting	JR-11-EC	22746	JR-11-EC-W	22846
1/4"	1/4"	-	Inverted Cone, Plain End	JR-12	22743	JR-12-W	22843
1/4"	1/4"	-	Inverted Cone, End Cutting	JR-12-EC	22744	JR-12-EC-W	22844
3/16"	11/64"	-	Ball	JR-13	22728	JR-13-W	22827
1/8"	1/2"	-	Cylindrical, Plain End	JR-14	22720	JR-14-W	22820
1/8"	1/2"	-	Cylindrical, End Cutting	JR-14-EC	22723	JR-14-EC-W	22823
1/4"	1/2"	-	Cylindrical, Ball Nose	JR-15	22731	JR-15-W	22831
1/4"	1/2"	.031"	Cone Forward Angle	JR-16	22742	JR-16-W	22842
1/4"	1/2"	-	Olive	JR-17	22733	JR-17-W	22833
1/4"	1/2"	.063"	Tree, Rounded Nose	JR-18	22736	JR-18-W	22836
1/4"	1/2"	-	Flame	JR-19	22739	JR-19-W	22839
1/4"	1/16"	-	Wheel, Side Cutting, Double Angle	JR-20	22747	JR-20-W	22847
1/8"	11/64"	-	Flame	JR-21	22737	JR-21-W	22837
1/8"	13/32"	F	Cone Forward Angle	JR-22	22740	JR-22-W	22840
1/8"	1/2"	-	Cylindrical, Ball Nose	JR-23	22729	JR-23-W	22829

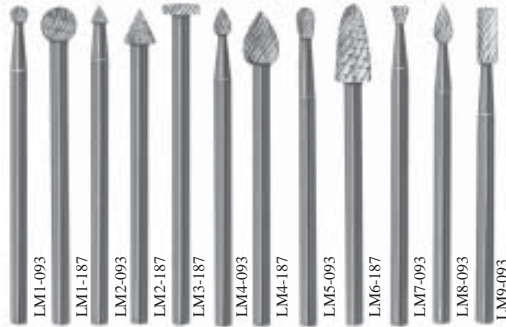

## Lab Mills™ 3/32" Shank Diameter – 1-5/8" Overall Length

Lab Mills are made in nine shapes to accomplish almost any small milling operation. Each shape is offered in six different head diameters. Specify shape and diameter when ordering. Set No. 60, EDP# 29666 (pictured above) – 12 tools of selected shapes and sizes (3/32" and 3/16" diameters). Ideal for small and micro part milling, deburring, and finishing. Severance Lab Mills™ are manufactured of high quality High Speed Steel and will outlast several ordinary dental lab style burrs with the added advantage that Severance Lab Mills™ can be reground to as good as new many times. Lab Mills™ speed production for manufacturers of jewelry, diesel injectors, aircraft parts, die castings, dies, molds, electronic equipment, medical components, dental lab, missile and space components, exc.



**High Speed Steel**  
**Lab Mills™**

Head Dia.	Flute Length	Nose Point, Flat, or Radius	Severance Tool Name	EDP Order Number
-----------	--------------	-----------------------------	---------------------	------------------

### Ball

1/16"	.047"	-	LM1-062	22620
3/32"	.078"	-	LM1-093	22621
1/8"	.094"	-	LM1-125	22622
3/16"	.88"	-	LM1-187	22623
1/4"	.250"	-	LM1-250	22624
5/16"	.313"	-	LM1-312	22625

### Cone, Pointed Nose, 25° C/L Angle

1/16"	.081"	-	LM2-062	22626
3/32"	.122"	-	LM2-093	22627
1/8"	.162"	-	LM2-125	22628
3/16"	.244"	-	LM2-187	22629
1/4"	.325"	-	LM2-250	22630
5/16"	.407"	-	LM2-312	22631

### Wheel (Saw)

1/16"	.016"	-	LM3-062	22632
3/32"	.019"	-	LM3-093	22633
1/8"	.032"	-	LM3-125	22634
3/16"	.046"	-	LM3-187	22635
1/4"	.062"	-	LM3-250	22636
5/16"	.078"	-	LM3-312	22637

### Bud Shape

1/16"	.087"	-	LM4-062	22638
3/32"	.130"	-	LM4-093	22639
1/8"	.178"	-	LM4-125	22640
3/16"	.261"	-	LM4-187	22641
1/4"	.348"	-	LM4-250	22642
5/16"	.435"	-	LM4-312	22643

### Pear Shape

1/16"	.100"	-	LM5-062	22644
3/32"	.150"	-	LM5-093	22645
1/8"	.206"	-	LM5-125	22646

Head Dia.	Flute Length	Nose Point, Flat, or Radius	Severance Tool Name	EDP Order Number
-----------	--------------	-----------------------------	---------------------	------------------

### Pear Shape CONTINUED

3/16"	.300"	-	LM5-187	22647
1/4"	.400"	-	LM5-250	22648
5/16"	.500"	-	LM5-312	22649

### Tree, Rounded Nose

1/16"	.125"	.018"	LM6-062	22650
3/32"	.188"	.025"	LM6-093	22651
1/8"	.250"	.031"	LM6-125	22652
3/16"	.375"	.047"	LM6-187	22653
1/4"	.500"	.062"	LM6-250	22654
5/16"	.625"	.078"	LM6-312	22655

### Inverted Cone

1/16"	.063"	-	LM7-062	22656
3/32"	.094"	-	LM7-093	22657
1/8"	.125"	-	LM7-125	22658
3/16"	.188"	-	LM7-187	22659
1/4"	.250"	-	LM7-250	22660
5/16"	.313"	-	LM7-312	22661

### Flame

1/16"	.126"	-	LM8-062	22662
3/32"	.188"	-	LM8-093	22663
1/8"	.256"	-	LM8-125	22664
3/16"	.375"	-	LM8-187	22665
1/4"	.500"	-	LM8-250	22666
5/16"	.625"	-	LM8-312	22667

### CYLINDER, Plain End

1/16"	.188"	-	LM9-062	22668
3/32"	.281"	-	LM9-093	22669
1/8"	.375"	-	LM9-125	22670
3/16"	.563"	-	LM9-187	22671
1/4"	.750"	-	LM9-250	22672
5/16"	.688"	-	LM9-312	22673

## High Speed Steel Extra Length Lab Mills™ Surgical Mills

3/32" Shank Diameter – 2-1/2" Overall Length

Ideal for small and micro part deburring and finishing.

Also know as: "Surgical Mills", or "Jordan Day™ Mills".

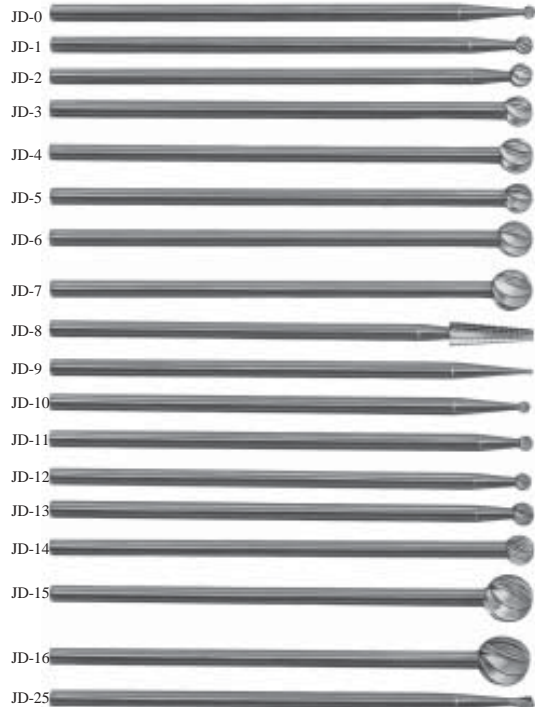
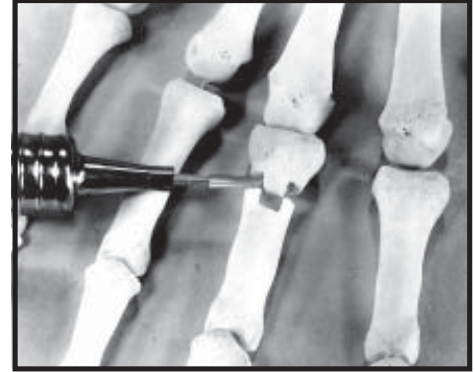

See Page 83 for our popular 12 piece Set No. 80 (EDP# 29680)

Head Diameter		Number of Teeth	Group Nomenclature	Severance Tool Name	EDP Order Number
Inches	MM				
.062"	1.6	6	Cutting Mills	JD-0	34310
.093"	2.4	6	Cutting Mills	JD-1	34311
.125"	3.2	6	Cutting Mills	JD-2	34312
.156"	4.0	6	Cutting Mills	JD-3	34313
.187"	4.7	6	Cutting Mills	JD-4	34314
.156"	4.0	8	Cutting Mills	JD-5	34315
.187"	4.7	8	Cutting Mills	JD-6	34316
.218"	5.5	8	Cutting Mills	JD-7	34317
.125"	3.2	8	Penetrating Mills	JD-8	34320
.039"	1.0	12	Polishing Mills	JD-9	34322
.059"	1.5	16	Polishing Mills	JD-10	34323
.078"	2.0	18	Polishing Mills	JD-11	34324
.090"	2.3	20	Polishing Mills	JD-12	34325
.118"	3.0	20	Polishing Mills	JD-13	34326
.156"	4.0	25	Polishing Mills	JD-14	34327
.250"	6.4	8	Cutting Mills	JD-15	34318
.281"	7.1	8	Cutting Mills	JD-16	34319
.078"	2.0	2	Penetrating Mills	JD-25	34321



## High Speed Steel Ball Nose Deburring Cutters 1/4" Shank Diameter

The **Plain** style is ideal for use in portable power tools for deburring holes as shown in the table. They produce approximately a 45° chamfer. When thrusting the tool into the hole at an angle, a large area of the mill is useful and not just a narrow circle.

The style **With Guide** is especially suited for deburring of oil holes in crankshafts because the guide on the end prevents the mill from slipping out of the hole and marring the bearing surface.

Plain		With Guide	
Head Dia.	Hole Size	Severance Tool Name	EDP Order Number
3/16"	1/8"	BBC	00240
1/4"	3/16"	CBC	00241
3/8"	1/4"	ECC	00242
1/2"	3/8"	GDC	00243
5/8"	7/16"	IEC	00244
		Severance Tool Name	EDP Order Number
		BBC-G	00245
		CBC-G	00246
		ECC-G	00247
		GDC-G	00248
		IEC-G	00249



# d-burrs<sup>™</sup> for Plastic Part Deburring

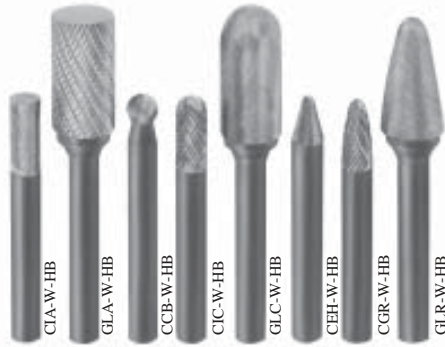

## Carbide d-burrs<sup>™</sup>

### 1/4" Shank Diameter

d-burrs<sup>™</sup> are designed for use on finishing plastic parts. Tools have the Severance EFHB cut for fine finishing of plastic and similar materials.

For heavy, fast, stock removal of Aluminum see Sever-Cuts<sup>™</sup> on pages 8-18.

Head Dia.	Flute Length	Nose Flat or Radius	Shape	Tooth Style	Severance Tool Name	EDP Order Number
1/4"	5/8"	-	Cyl. Flat End	EFHC	CIA-W-HB	22160
1/2"	1"	-	Cyl. Flat End	EFHC	GLA-W-HB	22149
1/4"	1/4"	-	Ball	EFHC	CCB-W-HB	22161
1/4"	5/8"	-	Cyl. Ball Nose	EFHC	CIC-W-HB	22158
1/2"	1"	-	Cyl. Ball Nose	EFHC	GLC-W-HB	22162
1/4"	3/8"	F	Tapered, Radius Nose	EFHC	CEH-W-HB	22163
1/4"	1/2"	.068"	Tree, Radius Nose	EFHC	CGR-W-HB	22159
1/2"	1"	.125"	Tree, Radius Nose	EFHC	GLR-W-HB	22164

JR-1-W-HB

JR-2-W-HB

JR-3-W-HB

JR-4-W-HB

JR-5-W-HB

JR-6-W-HB

JR-7-W-HB

JR-8-W-HB

JR-9-W-HB

JR-10-W-HB

JR-11-W-HB

JR-12-W-HB

JR-13-W-HB

JR-14-W-HB

JR-15-W-HB

JR-16-W-HB

JR-17-W-HB

JR-18-W-HB

JR-19-W-HB



## Carbide Junior d-burrs<sup>™</sup>

### 1/8" Shank Diameter - 1-5/8" Overall Length

Tools are supplied with a Herringbone Cut

Head Dia.	Head Length	Nose Point, Flat or Radius	Tool Shape	Severance Tool Name	EDP Order Number
3/16"	5/8"	-	Cylindrical, Plain End	JR-1-W-HB	22851
1/4"	1/2"	-	Cylindrical, Plain End	JR-2-W-HB	22852
1/8"	3/32"	-	Ball	JR-3-W-HB	22853
1/4"	3/16"	-	Ball	JR-4-W-HB	22855
3/16"	5/8"	-	Cylindrical, Ball Nose	JR-5-W-HB	22857
3/16"	5/8"	P	Cone Forward Angle	JR-6-W-HB	22868
3/16"	3/8"	-	Olive	JR-7-W-HB	22859
1/8"	5/16"	.031"	Tree, Rounded Nose	JR-8-W-HB	22861
3/16"	3/8"	.047"	Tree, Rounded Nose	JR-9-W-HB	22862
3/16"	3/8"	-	Flame	JR-10-W-HB	22865
3/8"	3/64"	-	Wheel, Cylindrical, Plain End	JR-11-W-HB	22871
1/4"	1/4"	-	Inverted Cone, Plain End	JR-12-W-HB	22870
3/16"	11/64"	-	Ball	JR-13-W-HB	22854
1/8"	1/2"	-	Cylindrical, Plain End	JR-14-W-HB	22850
1/4"	1/2"	-	Cylindrical, Ball Nose	JR-15-W-HB	22858
1/4"	1/2"	.031"	Cone Forward Angle	JR-16-W-HB	22869
1/4"	1/2"	-	Olive	JR-17-W-HB	22860
1/4"	1/2"	.063"	Tree, Rounded Nose	JR-18-W-HB	22863
1/4"	1/2"	-	Flame	JR-19-W-HB	22866
1/8"	11/64"	-	Flame	JR-21-W-HB	22864
1/8"	13/32"	F	Cone Forward Angle	JR-22-W-HB	22867
1/8"	1/2"	-	Cylindrical, Ball Nose	JR-23-W-HB	22856



## Carbide Bore Mills™

Severance Bore Mills™ are designed with a special fine double cut, to be used in place of mounted grinding wheels in jig grinding applications. Their convex shape provides rapid stock removal on cast iron, steel, nonferrous and many nonmetallic materials. Bore Mills™ are operated at the same speeds and feeds as grinding wheels and are capable of producing surface finishes in the 10 to 12 micro-inch range.

Head Dia.	Shank Dia.	Overall Length	Severance Tool Name	EDP Order Number
.047"	1/8"	1-1/2"	BM-3-W	00250
.078"	1/8"	1-1/2"	BM-5-W	00251
.109"	1/8"	1-1/2"	BM-7-W	00252
.125"	3/16"	2"	BM-8-W	00253
.172"	3/16"	2"	BM-11-W	00254

Head Dia.	Shank Dia.	Overall Length	Severance Tool Name	EDP Order Number
.250"	1/4"	2"	BM-16-W	00255
.312"	5/16"	2"	BM-20-W	00256
.375"	3/8"	2"	BM-24-W	00257
.500"	1/2"	2"	BM-32-W	00258

NOTE: All Bore Mills™ are TiN coated at no extra Charge.



## Carbide Micro-Mills™

Micro-Mills™ are similar in application to the Bore Mills™, but are used for finishing in the 6 to 8 micro-inch range. Micro-Mills™ are designed with a fine cut with chip breakers. These mills are intended for applications where there is a light amount of stock removal required and work best on ferrous, non-work hardening materials. Micro-Mills™ should not be oscillated. Cut on the in-feed and burnish on the out-feed. Both Micro-Mills™ and Bore Mills™ will outlast grinding wheels, particularly on demanding operations such as chamfering and counter-boring.

Head Dia.	Shank Dia.	Overall Length	Severance Tool Name	EDP Order Number
.047"	1/8"	1-1/2"	MW-4	21120
.065"	1/8"	1-1/2"	MW-5	21130
.078"	1/8"	1-1/2"	MW-6	21121
.096"	1/8"	1-1/2"	MW-7	21131
.109"	1/8"	1-1/2"	MW-8	21122
.127"	1/8"	1-1/2"	MW-9	21132
.130"	3/16"	2"	MW-10	21123
.158"	3/16"	2"	MW-11	21133
.172"	3/16"	2"	MW-12	21124

Head Dia.	Shank Dia.	Overall Length	Severance Tool Name	EDP Order Number
.190"	3/16"	2"	MW-13	21134
.195"	1/4"	2"	MW-14	21125
.219"	1/4"	2"	MW-16	21126
.253"	1/4"	2"	MW-18	21135
.281"	1/4"	2"	MW-20	21127
.312"	1/4"	2"	MW-22	21136
.344"	1/4"	2"	MW-24	21128
.375"	1/4"	2"	MW-28	21137
.469"	1/4"	2"	MW-32	21129

NOTE: All Micro-Mills™ are TiN coated at no extra charge.

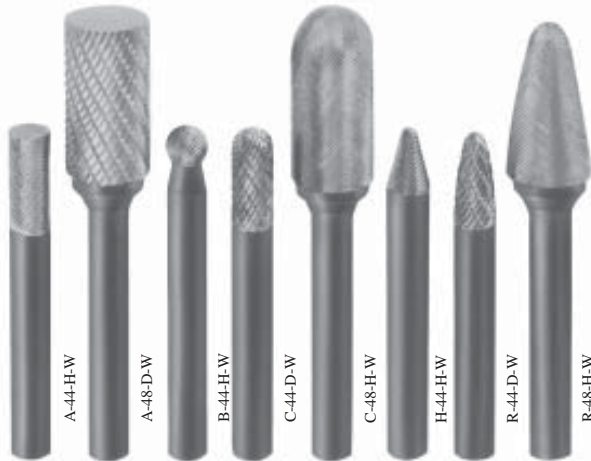

Carbide Die-Car Mills™  
Come with 1/4" shanks

## Carbide Di-Car Mills™

Special herringbone or extra fine double cut tooth patterns are designed to replace the use of a grinding wheel. Intended for application where there is light stock removal and a very good finish is required. Works best on ferrous, non-work hardening materials. Can be used in either hand or machine applications.

Head Dia.	Flute Length	Nose Flat or Radius	Shape	Tooth Style	Severance Tool Name	EDP Order Number
1/4"	5/8"	-	Cyl. Flat End	Extra Fine Herringbone Cut	A-44-H-W	22150
1/2"	1"	-	Cyl. Flat End	Extra Fine Double Cut	A-48-D-W	22151
1/4"	1/4"	-	Ball	Extra Fine Herringbone Cut	B-44-H-W	22152
1/4"	5/8"	-	Cyl. Ball Nose	Extra Fine Double Cut	C-44-D-W	22153
1/2"	1"	-	Cyl. Ball Nose	Extra Fine Herringbone Cut	C-48-H-W	22154
1/4"	3/8"	F	Tapered, Radius Nose	Extra Fine Herringbone Cut	H-44-H-W	22155
1/4"	1/2"	.068"	Tree, Radius Nose	Extra Fine Double Cut	R-44-D-W	22156
1/2"	1"	.0125	Tree, Radius Nose	Extra Fine Herringbone Cut	R-48-H-W	22157

\* 1/2" tools have 1/4" alloy steel, hardened shanks; all 1/4" tools are solid carbide.



## Die Mills

Die Mills are made with the shank and the cutting head of the same diameter. They are used extensively in template work, where the shank serves as a guide, and in other profiling operations. Die Mills may be reground many times for a long service life. When reground by Severance, a portion of the shank is reduced to match the new cutting diameter.

### Carbide Die Mills

### High Speed Steel Die Mills

Head Dia.	Shank Dia.	Flute Style
3/32"	3/32"	Standard Cut
1/8"	1/8"	Double Cut
1/8"	1/8"	Standard Cut
1/8"	1/8"	Standard Cut
5/32"	3/16"	Double Cut
5/32"	3/16"	Standard Cut
3/16"	3/16"	Double Cut
3/16"	3/16"	Standard Cut
1/4"	1/4"	Double Cut
1/4"	1/4"	Standard Cut
5/16"	5/16"	Double Cut
5/16"	5/16"	Standard Cut
3/8"	3/8"	Double Cut
3/8"	3/8"	Standard Cut
7/16"	7/16"	Double Cut
7/16"	7/16"	Standard Cut
1/2"	1/2"	Double Cut
1/2"	1/2"	Standard Cut

Flute Length	Overall Length	Severance Tool Name	EDP Order Number
-	-	-	-
1/2"	1-1/2"	4A-DIE-W	17260
1/2"	1-1/2"	AGA-DIE-W	17262
-	-	-	-
1/2"	2"	5A-DIE-W	17264
1/2"	2"	5GA-DIE-W	17266
3/4"	2"	6A-DIE-W	17268
3/4"	2"	BJA-DIE-W	17270
3/4"	2"	8A-DIE-W	17272
3/4"	2"	CJA-DIE-W	17274
13/16"	2"	10A-DIE-W	17276
3/4"	2"	DJA-DIE-W	17278
1"	2-1/2"	12A-DIE-W	17280
1"	2-1/2"	ELA-DIE-W	17282
1"	2-1/2"	14A-DIE-W	17284
1"	2-1/2"	FLA-DIE-W	17286
1"	2-1/2"	16A-DIE-W	17288
1"	2-1/2"	GLA-DIE-W	17290

Flute Length	Overall Length	Severance Tool Name	EDP Order Number
1/4"	1-5/8"	3/32CA-DIE	17310
-	-	-	-
1/2"	1-5/8"	AGA-DIE	17312
1-1/2"	3"	APA-DIE	17314
-	-	-	-
-	-	-	-
-	-	-	-
3/4"	2"	BJA-DIE	17316
-	-	-	-
3/4"	2-1/4"	CJA-DIE	17318
-	-	-	-
3/4"	2-1/4"	DJA-DIE	17320
-	-	-	-
7/8"	2-1/4"	EKA-DIE	17322
-	-	-	-
7/8"	2-1/4"	FLA-DIE	17324
-	-	-	-
1"	2-1/2"	GLA-DIE	17326