

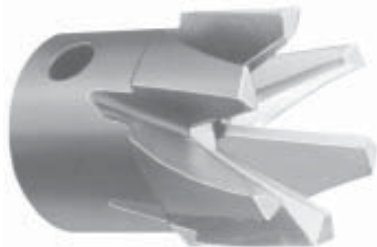

ED-1



EDE-2



ED-T2

## Electrode Forming Cutters For "Spot Weld" Electrodes

Reconditioning Electrode tips is an economical solution that minimizes downtime. Replacing worn tips with new electrode tips can be costly and time consuming. But reconditioning the worn tip will extend the life of your electrodes, and cuts down wasted production time.

**Electrode Forming Cutters** are available in threaded, extended, and flush styles.

- **Threaded (ED-1)** cutters are ideal where the center-to-center distance between electrodes is less than 1", as is the case in many multiple-point and short-stroke stationary welders. Comes with an adjustable nose flat.

- **Extended (EDE-2)** cutters are ideal where the center-to-center distance between electrodes is less than 1", as is the case in many multiple-point and short-stroke stationary welders.

- **Flush (ED-T2)** cutters allow access in confined areas, requiring a minimum clearance of only 3/4" between welding faces.

Severance can make up cutters to fit any electrode dresser holder, and to produce any desired tip shape. Severance makes high-quality double end type dressers to be used on robotics and automated machinery. Combinations of radius and angles can be produced to obtain the optimum in strength and repeated high quality welds. To request a quotation on nonstandard cutters, please specify equipment used and provide a sketch of the required tip shape.

See Special Forms Page 65-66

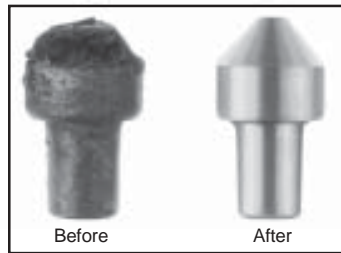

Before

After

### High Speed Steel

Threaded Style Electrode Forming Cutter

Shape Centerline Angle	Dia. of Flat Nose Cutting Insert And Comb. Stop	Severance Tool Name	EDP Order Number
30°	3/16"	ED-1	17470
30°	1/8"	ED-2	17471

### High Speed Steel

Extended Style Electrode Forming Cutter

Shape Centerline Angle	Dia. of Flat Nose Cutting Insert And Comb. Stop	Severance Tool Name	EDP Order Number
30°	1/8"	EDE-1	17490
30°	3/16"	EDE-2	17491
30°	1/4"	EDE-3	17492
5/16 Radius	1/4"	EDE-6	17493



Air tools not included with cutters

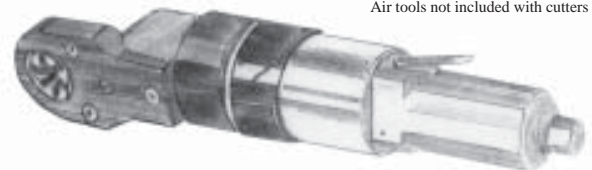

### High Speed Steel

Flush Style Electrode Forming Cutter

Shape Centerline Angle	Dia. of Flat Nose Cutting Insert And Comb. Stop	Severance Tool Name	EDP Order Number
Reform No. 1 Pointed Tips	3/16"	ED-T1	17530
Reform No. 2 Pointed Tips	1/4"	ED-T2	17531

## Specialty Electrode Cutter Forms

For "Spot Weld" Electrodes (For styles/shapes of actual cutters, see bottom of next page).

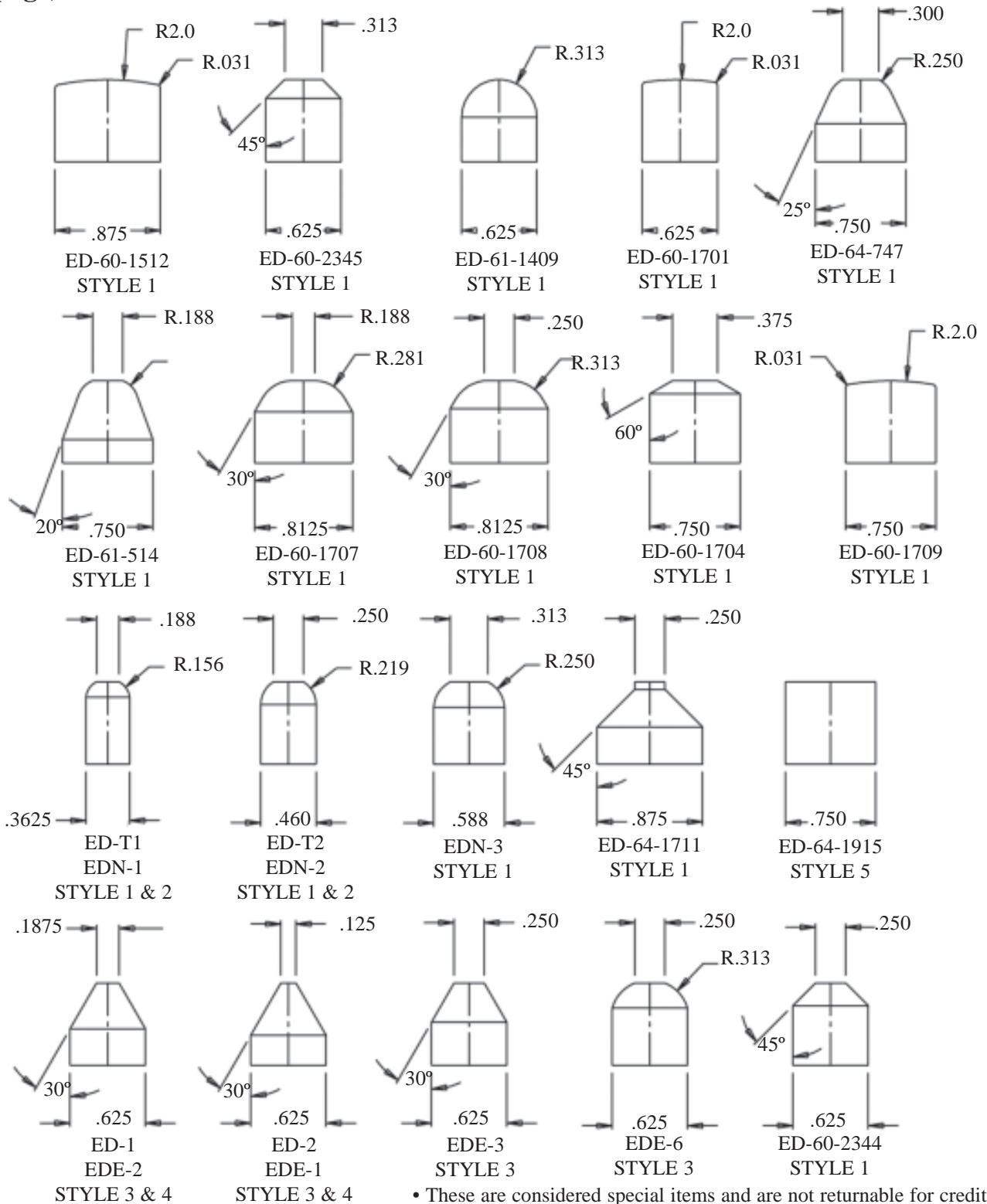

• These are considered special items and are not returnable for credit.

## Specialty Electrode Cutter Forms (Continued..)

For "Spot Weld" Electrodes (For styles/shapes of actual cutters, see bottom of page).

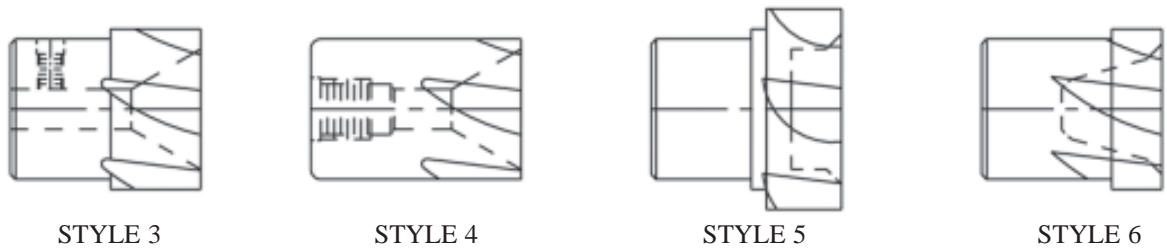
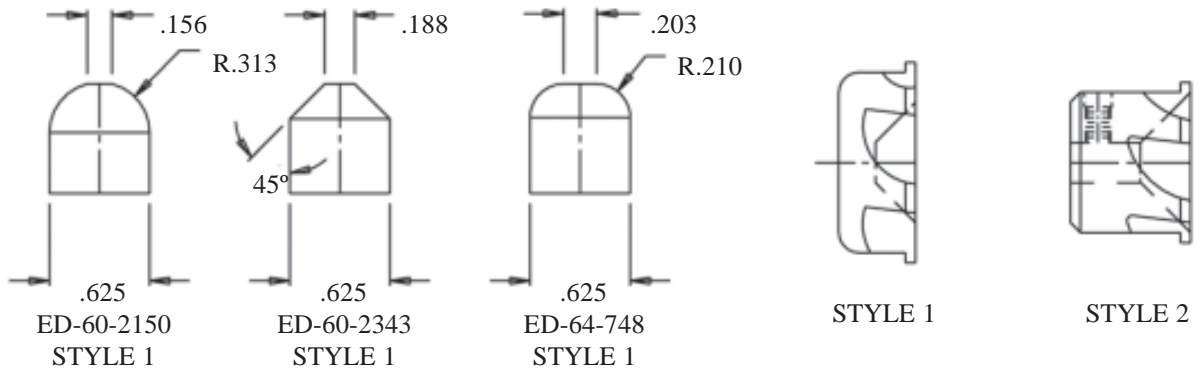
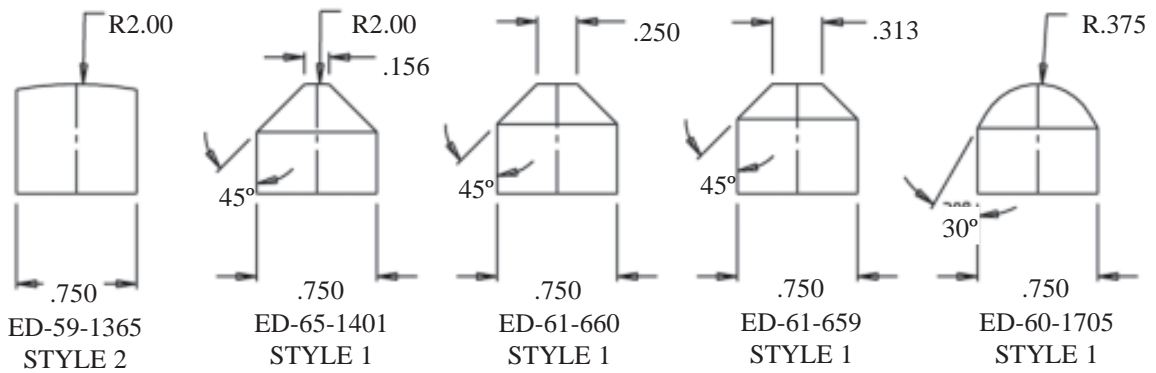
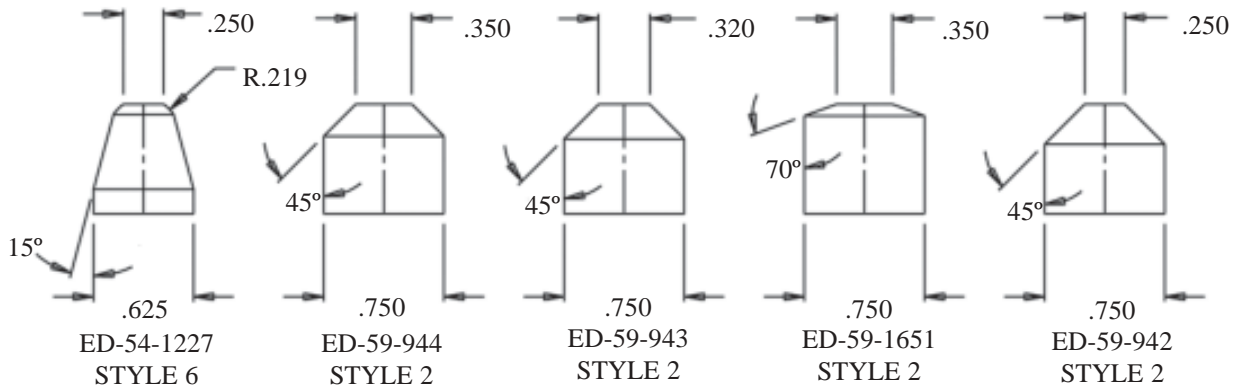

• These are considered special items and are not returnable for credit.