

Patent Pending

Quick Change Countersink System

Severance Tool introduces the new 3N1-QC™ Quick Change Countersink System. Featuring standard shanks in 4", 6", and 8" over all lengths, this system is designed to allow quick change of the countersink head for fast tool changes while maintaining dimensional integrity. The quick change head has a positive lock up on a ground taper and with a threaded lock, tool changes are fast and simple. All 3N1-QC™ threaded countersinks are factory resharpenable.

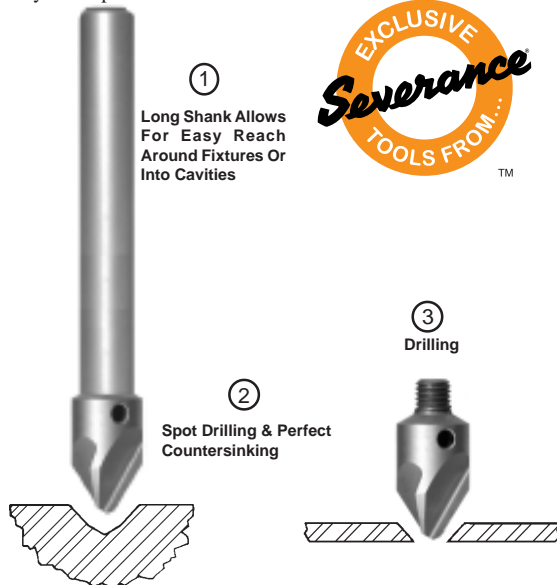

How Does a 3N1-QC™ Work?

Severance has developed a unique tool which combines the functions of a drill point starter and true countersink in a quick change tool. A conventional thin-web drill point is blended into two flutes of a four-flute chatter-free™ countersink ... to perform two or all three of the steps in a spot-drill-countersink and edge chamfer operations. Once you have established a tool in a chuck, you can leave the shank in place and quickly change out the dull 3N1® head with a sharp 3N1®, fast change over. On thin material, such as illustration (2) below, drilling could be optional.

Benefits of a 3N1-QC™ Drill Point Countersink

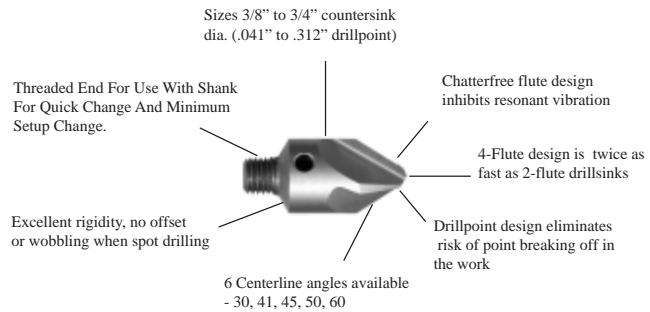

Save steps, setup, production time, and lower scrap rates with a Severance 3N1-QC™ Spotting tool. Specifically designed to give a true start spot and an accurate countersink chamfer on your part.

3N1-QC™ Drill Point Countersinks

High Speed Steel

C'sink Dia.	Overall Length	Thread Size	Centerline Angle												
			30°		41°		45°		50°		60°				
			Included Angle						60°		82°		90°		100°
Severance Name			Order Number	Order Number	Order Number	Order Number	Order Number	Order Number	Order Number	Order Number	Order Number	Order Number	Order Number		
3/8"	1-5/32"	1/4"-28	3N1-QC-3/8	01800	01810	01820	01830	01840							
7/16"	1-5/32"	1/4"-28	3N1-QC-7/16	01801	01811	01821	01831	01841							
1/2"	1-5/32"	1/4"-28	3N1-QC-1/2	01802	01812	01822	01832	01842							
5/8"	1-5/32"	1/4"-28	3N1-QC-5/8	01803	01813	01823	01833	01843							
3/4"	1-13/16"	1/4"-28	3N1-QC-3/4	01804	01814	01824	01834	01844							

Note: When Ordering 3N1-QC™ Make Sure To Specify Angle, Example (3N1-QC-3/8-45)

Shanks for 3N1-QC™ Cutters

Thread Size	Shank		Overall Length	Shoulder Dia.	Severance Shank Name	EDP Order Number
	Frac.	Dec.				
1/4"-28	1/4"	.250	3-1/2"	7/16"	FM-2 Shank	34235
1/4"-28	1/2"	.500	6"	1/2"	QMS-2x6 Shank	34239
1/4"-28	1/2"	.500	8"	1/2"	QMS-2x8 Shank	34240
3/8"-24	1/4"	.250	3-1/2"	9/16"	FM-3 Shank	34236
3/8"-24	5/8"	.625	6"	5/8"	QMS-3x6 Shank	34241
3/8"-24	5/8"	.625	8"	5/8"	QMS-3x6 Shank	34242

**Spot Drill
Countersink
Quick Change**
The 3N1-QC™ System

For Assistance, Contact Your Local Dealer:



Severance Tool Ind. Inc. reserves the right that all prices and tools are subject to change or correction without notice.

Severance® Tool Industries, Inc.

3790 Orange Street
P.O. Box 1866
Saginaw, MI 48605



Phone: (989) 777-5500

Fax: (989) 777-0602